

**SURVEY CONTROL DATA**

- HORIZONTAL CONTROL:**  
 1. HORIZONTAL CONTROL FOR THIS SURVEY ARE BASED ON THE OKLAHOMA STATE PLANE COORDINATE SYSTEM, NORTH ZONE 3501 - NAD 83 DATUM.  
 2. ACCURACY - 3RD ORDER
- VERTICAL CONTROLS:**  
 3. LEVEL DATUM IS MEAN SEA LEVEL (UCS&GS) NAVD 88  
 4. THE LINEAR UNIT IS U.S. SURVEY FOOT.
5. PERMANENT BENCHMARK - LLS1  
 CUT "X" ON TOP OF CONCRETE STORM STR.  
 LOCATED 19 FEET NORTH OF THE CENTERLINE OF DEWEY AVENUE AND 56 FEET WEST OF THE CENTERLINE OF WATCHORN ST.

**48 HOURS BEFORE YOU DIG**  
 CALL OKIE 1-800-522-6543  
 UTILITIES LOCATION SHOWN ON PLAN AND PROFILE WERE OBTAINED FROM INFORMATION PROVIDED BY UTILITY SYSTEM OWNER IN CONJUNCTION WITH EXISTING PHYSICAL FEATURES VISIBLE AT THE TIME OF THE TOPOGRAPHIC SURVEY. LOCATIONS MUST BE VERIFIED BY THE CONTRACTOR PRIOR TO CONSTRUCTION



UTILITY CONTACTS	
CITY OF SAPULPA, OKLAHOMA PUBLIC WORKS ADMIN., TAMMI GOLDEN 424 E. HOBSON AVE. SAPULPA, OKLAHOMA 74066 (918) 248-5928 (918) 227-5132 (FAX)	CITY OF SAPULPA, OKLAHOMA ENVIRO. ADMIN., BROOKE KONONCHUK 424 E. HOBSON AVE. SAPULPA, OKLAHOMA 74066 (918) 248-5934 (918) 227-5132 (FAX)
CITY OF SAPULPA, OKLAHOMA STREET/STORMWATER, RENEE JAMES 424 E. HOBSON AVE. SAPULPA, OKLAHOMA 74066 (918) 216-1175 (918) 227-5132 (FAX)	ONG (GOV'T RELOCATIONS) ATTN: TIM HELBIG 5848 EAST 15TH STREET TULSA, OKLAHOMA 74112 (918) 831-8215 (918) 949-5735 (CELL)
COX COMMUNICATIONS ATTN: CHRIS LONG 11811 E. 51ST STREET TULSA, OK 74146 (918) 286-4666 (918) 286-4018 (FAX)	ONG (EXISTING CONST.) ATTN: DJANE COOPER P.O. BOX 871 TULSA, OKLAHOMA 74102 (918) 451-3814 (918) 451-0899 (FAX)
WINDSTREAM COMMUNICATION ATTN: JOSEPH MINOR 1814 W. TACOMA STREET BROKEN ARROW, OK 74012 (918) 588-4960	AEP/PSO ATTN: LONNY HICKS 5223 S. GARNETT RD TULSA, OK 74149 (918) 599-2912 (918) 247-8466 (FAX)

DESIGN DATA	
SECONDARY ARTERIAL	= 2.041
AADT 2021	=
PROJ. AADT 2041	=
DESIGN SPEED	= 25 MPH
MAX VERTICAL GRADE	= 4.0%
MIN. VERTICAL GRADE	= 0.4%
MIN. K CREST	= 12
MIN. K SAG	= 26

# CITY OF SAPULPA













































## STREET RECONSTRUCTION OF MAYFIELD STREET FROM THOMPSON AVENUE TO DEWEY AVENUE CREEK COUNTY

INDEX OF SHEETS	
DESCRIPTION	SHEET NO.
TITLE SHEET	1
PAY ITEMS & NOTES	2
SUMMARY SHEET	3
TYPICAL SECTIONS	4
ADDITIONAL DETAILS	5
STORMWATER POLLUTION PREVENTION PLAN	6
DRAINAGE AREA MAP	7
DEMOLITION SHEETS	8-9
RIGHT OF WAY SHEETS	10-11
PLAN & PROFILE SHEETS	12-14
STORM PLAN & PROFILE	15-16
INTERSECTION DETAILS	17-18
SURVEY DATA SHEETS	19-22
CROSS SECTIONS	XS1-XS6

ODOT STANDARDS			
2019 ROADWAY		2009 TRAFFIC	
SSS-2-0	MJB-4-1	TCS1-1-01	TCS16-1-00
TSC1-4-0	PRM-1-1	TCS2-1-00	TCS19-1-01
TSC2-4-0	SPI-5-1	TCS3-1-01	PM1-1-03
ASCD-6-0	FPI-5-1	TCS4-1-01	RSD1-1-00
CSCD-6-1	SPB-2-1	TCS5-1-00	GMS1-1-00
LECS-5-1	MI-4-1	TCS6-1-02	SSP1-1-02
WCR-4-1	PDT-2-0	TCS7-1-02	
TWD-2-1		TCS8-1-00	
PCI-1-0		TCS9-1-01	
PCES-5-0		TCS10-1-00	
CDIP-2-1		TCS11-1-01	
CI-2-1		TCS12-1-00	
SSIF-5-0		TCS13-1-00	
CIG-4-0		TCS14-1-00	
MFC-5-0		TCS15-1-00	

SAPULPA CITY COUNCIL	
MAYOR	CRAIG HENDERSON
VICE MAYOR	CARLA GUNN
MEMBER	JOSEPH HALE
MEMBER	LOUIS MARTIN, JR.
MEMBER	BRUCE BLEDSOE

**TOPOGRAPHIC LEGEND**

- |   |   |
|---|---|
|  AIR CONDITIONER UNIT        |  FENCE                       |
|  GROUND TRANSFORMER          |  EASEMENT                    |
|  LIGHT POLE                  |  BUILDING SET BACK LINE      |
|  TRANSFORMER POLE            |  SANITARY SEWER LINE (ATLAS) |
|  POWER POLE                  |  STORM DRAIN LINE            |
|  ELECTRIC METER              |  OVERHEAD TELEPHONE LINE     |
|  DOWN GUY                    |  UNDERGROUND TELEPHONE LINE  |
|  TELEPHONE RISER             |  SANITARY SEWER LINE         |
|  COMMUNICATIONS BACKUP RISER |  OVERHEAD ELECTRIC LINE      |
|  GAS METER                   |  GROUND SURFACE CONTOUR      |
|  GAS VALVE                   |  CURB AND GUTTER             |
|  GAS VENT                    |  SURFACE DRAINAGE FLOWLINE   |
|  SPRINKLER HEAD              |  TREE DRIP LINE              |
|  SPRINKLER VALVE             |  SHRUB LINE                  |
|  FIRE HYDRANT                |  WATER LINE                  |
|  COMMUNICATIONS VAULT        |  WATER LINE (ATLAS)          |
|  SANITARY SEWER MANHOLE      |  CONCRETE                    |
|  SANITARY SEWER CLEANOUT     |  ASPHALT                     |
|  SANITARY SEWER LAMPHOLE     |  GRAVEL                      |
|  STORM DRAIN MANHOLE         |   |
|  WATER METER                 |   |
|  WATER VALVE BOX             |   |
|  GUARD POST                  |   |
|  MAILBOX                     |   |
|  FLAG POLE                   |   |
|  SIGN                        |   |

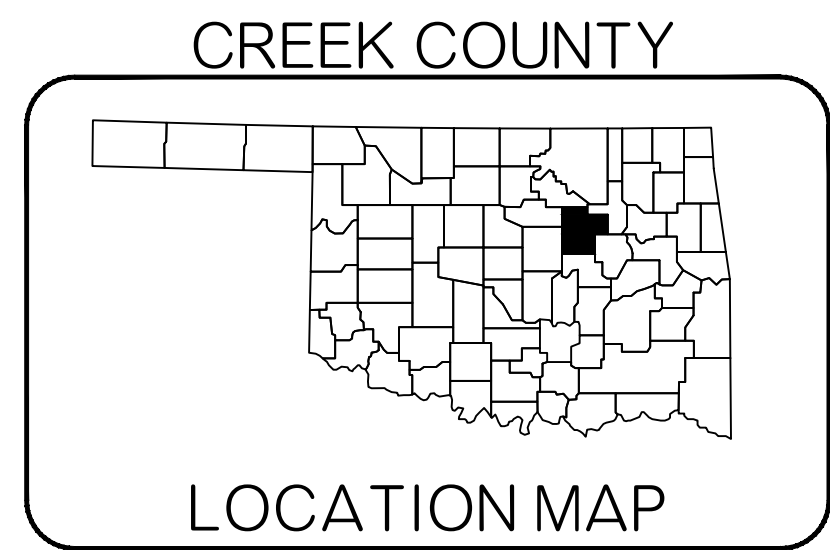

PREPARED AND SUBMITTED BY:  
**MCE McCLELLAND**  
**CONSULTING**  
**ENGINEERS, INC.**  
 DESIGNED TO SERVE

4606 S. Garnett Rd., Suite 401 Tulsa, OK 74146  
 PH# 918.619.6803 Fax # 918.340.5395  
 HTTP://WWW.MCE.US.COM  
 CERTIFICATE OF AUTHORIZATION #5917 EXPIRES 6-30-23

CITY OF SAPULPA STANDARD CONSTRUCTION SPECIFICATIONS, AUGUST 21, 2014 SHALL GOVERN ALL CONSTRUCTION AS SUPPLEMENTED BY OKLAHOMA STANDARD SPECIFICATIONS FOR HIGHWAY CONSTRUCTION, APPROVED BY THE DEPARTMENT OF TRANSPORTATION 2019.

APPROVED

STEVE HARDT \_\_\_\_\_ DATE  
 PUBLIC WORKS DIRECTOR

PREPARED BY  
 DEVIN RANDALL, P.E. \_\_\_\_\_ DATE  
 MCCLELLAND CONSULTING ENGINEERS, INC

THIS DOCUMENT IS PRELIMINARY IN NATURE  
 AND IS NOT A FINAL, SIGNED AND SEALED DOCUMENT

GENERAL CONSTRUCTION NOTES

ALL TREES, BRUSH, AND OTHER DEBRIS THAT MIGHT INTERFERE WITH THE FLOW OF WATER SHALL BE CLEANED OUT TO THE RIGHT-OF-WAY LINE, AT EACH STRUCTURE AND BRIDGE, IN A MANNER APPROVED BY THE ENGINEER. ALL COST TO BE INCLUDED IN OTHER ITEMS OF WORK.

ALL FLOWLINES THAT ARE TO BE FILLED SHALL BE THOROUGHLY TAMPED BEFORE CONSTRUCTION OR EXTENSION OF DRAINAGE STRUCTURES. ALL COST TO BE INCLUDED IN OTHER ITEMS OF WORK.

IN ORDER TO ALLEVIATE DUST CONDITIONS DURING GRADING OPERATIONS AND BEFORE PAVEMENT WORK IS COMPLETED, THE CONTRACTOR SHALL SPRINKLE GRADING AT INTERVALS APPROVED BY THE ENGINEER. ALL COST TO BE INCLUDED IN OTHER ITEMS OF WORK.

THE CONTRACTOR SHALL NOT WASTE ANY EXCESS EXCAVATION UNTIL ALL PLANNED EMBANKMENTS AND BACKFILLS ARE COMPLETED. EXCESS UNCLASSIFIED EXCAVATION MATERIAL DETERMINED BY THE ENGINEER TO BE SUITABLE FOR BACKFILL SHALL BE USED TO REDUCE ANY UNCLASSIFIED BORROW NEEDED. COST OF SECOND HANDLING SHALL BE INCLUDED IN OTHER ITEMS OF WORK. ANY REMAINING EXCESS EXCAVATION SHALL BECOME THE PROPERTY OF THE CONTRACTOR AND BE DISPOSED OF IN A MANNER APPROVED BY THE ENGINEER.

IN ACCORDANCE WITH THE OKLAHOMA UNDERGROUND FACILITIES DAMAGE PREVENTION ACT THE CONTRACTOR SHALL NOTIFY THE OKLAHOMA ONE-CALL SYSTEM, INC. 48 HOURS PRIOR TO BEGINNING EXCAVATION. OKLAHOMA ONE-CALL SYSTEM, INC. "CALL OKIE" 1-800-55-6543 OR 811.

AREAS ON WHICH SALVAGED TOPSOIL IS TO BE REPLACED SHALL HAVE 18-46-0 FERTILIZER APPLIED, AT THE RATE OF 150 POUNDS PER ACRE, JUST PRIOR TO THE REPLACEMENT OF SALVAGED TOPSOIL.

AT THE BEGINNING OF TURFING OPERATIONS, ANY AREAS INCLUDED IN PLANNED QUANTITIES THAT HAVE GROWN A SATISFACTORY VOLUNTEER TURF OF PERENNIAL GRASS, AS DETERMINED BY THE ENGINEER SHALL BE FERTILIZED AND WATERED AS CALLED FOR ON THE PLANS, BUT SHALL NOT BE SEEDED, SODDED, OR SPRIGGED.

THE CONTRACTOR SHALL KEEP THE OPEN TRENCH DRAINED. COST TO BE INCLUDED IN OTHER ITEMS OF WORK.

SURFACING OF RETURNS, UNLESS OTHERWISE SHOWN ON THE PLANS, SHALL BE OF THE SAME MATERIAL (BASE AND SURFACE) AS THAT OF THE ABUTTING SHOULDER OF THE MAINLINE. BASE AND SURFACE THICKNESS SHALL BE THE THICKNESS SHOWN ON PLANS.

PRIOR TO FINAL ACCEPTANCE, ALL EXPOSED CURB SURFACES SHALL BE CLEANED OF ALL DISCOLORATION SUCH AS ASPHALT STAIN, TIRE MARKS, OR OTHER DISFIGUREMENT.

EXCESS ASPHALT AT JOINTS AND CRACKS IN EXISTING PAVEMENT SHALL BE REMOVED FLUSH TO TOP OF PAVING IN A MANNER APPROVED BY THE ENGINEER.

THE CONTRACTOR SHALL KEEP THE OPEN TRENCH DRAINED. COST TO BE INCLUDED IN OTHER ITEMS OF WORK.

THE CONTRACTOR SHALL REMOVE AND RESET MAILBOXES AS NECESSARY. MAILBOXES ARE TO BE MAINTAINED IN AN UPRIGHT POSITION AND ACCESSIBLE TO MAIL CARRIER'S CAR DURING CONSTRUCTION. ANY DAMAGE TO BOXES OR SUPPORTS SHALL BE REPAIRED BY THE CONTRACTOR. ALL COST TO BE INCLUDED IN OTHER ITEMS OF WORK.

ALL FEATURES OF THIS PROJECT INCLUDING, BUT NOT LIMITED TO, PATHS, SIDEWALKS, CURB RAMPS, AND CROSSWALK MARKINGS WILL COMPLY WITH PUBLIC RIGHTS-OF-WAY ACCESSIBILITY GUIDELINES (PROWAG), PUBLISHED JULY 26, 2011. WHERE SPECIAL LIMITATIONS OF EXISTING FEATURES WITHIN THE LIMITS OF THE PROJECT PREVENT FULL COMPLIANCE WITH PROWAG, THE CONTRACTOR WILL IMMEDIATELY NOTIFY THE ENGINEER UPON DISCOVERY OF SUCH FEATURES. THE CONTRACTOR WILL NOT PROCEED WITH ANY OF THE WORK, WHICH IS NOT IN FULL COMPLIANCE WITH PROWAG, WITHOUT PRIOR WRITTEN APPROVAL FROM THE ENGINEER. ANY WORK WHICH IS NOT PERFORMED WITHIN THE GUIDELINES OF PROWAG FOR THE CONTRACTOR DOES NOT HAVE WRITTEN APPROVAL WILL BE CORRECTED AT THE CONTRACTOR'S EXPENSE.

THE CROSS SLOPE FOR PATHS, SIDEWALKS, AND RAMPS WITHIN THE LIMITS OF AN ACCESSIBLE ROUTE WILL NOT EXCEED 1:50 OR 2%.

RAMP LONGITUDINAL SLOPES WILL NOT EXCEED 1:12 OR 8.33%.

THE CONTINUOUS PATH'S CROSS SLOPE WILL NOT EXCEED 2% THROUGH DRIVEWAYS. SEE DRIVEWAY DETAIL ON ODOT ROADWAY STANDARD WCR-4 AND SPECIAL DRIVEWAY DETAILS.

SIDEWALKS AND RAMP LOCATIONS HAVE BEEN DEPICTED WITHOUT KNOWLEDGE OF ULTIMATE UTILITY STRUCTURE LOCATIONS. LOCATIONS WILL BE ADJUSTED TO AVOID ABOVE GRADE UTILITY STRUCTURES SUCH AS UTILITY POLES, RISERS, GUY ANCHORS, AND OTHER ABOVE GRADE APPURTENANCES. NO SUCH STRUCTURES WILL BE ALLOWED WITH THE PEDESTRIAN ACCESS ROUTE AS DEFINED PROWAG.

ROADWAY PAY ITEM NOTES

(R-1) PAYMENT FOR THIS ITEM WILL BE BASED ON PLAN QUANTITY ONLY. SEE SECTION 109.01B OF THE STANDARD SPECIFICATIONS.

(R-4) AN ESTIMATED QUANTITY OF 220 C.Y. TOPSOIL TO BE RESERVED FOR REPLACEMENT OF APPROXIMATELY 5" ON COMPLETED FORESLOPES, DITCHES, AND BACKSLOPES. THIS QUANTITY IS INCLUDED IN THE EARTHWORK BALANCE. ANY ADDITIONAL EXCAVATION REQUIRED IN CUT SECTIONS TO ALLOW FOR PLACEMENT OF TOPSOIL TO FINAL GRADE, SHALL BE INCLUDED IN THE PRICE BID.

(R-6) FOR SOLID SLAB SODDING PRICE BID TO INCLUDE COST OF 16-20-10 FERTILIZER, ESTIMATED AT 200 POUNDS PER 1000 SQ. YD.

(R-7) FOR SOLID SLAB SODDING PRICE BID TO INCLUDE COST OF WATERING, ESTIMATED AT 40 GALLONS PER SQ. YD.

(R-8) PRICE BID TO INCLUDE COST OF ALL NECESSARY MAINTENANCE, MAINTAINING DEVICE IN PROPER UPRIGHT POSITION, REMOVAL OF DEVICE, AND REMOVAL OF SEDIMENT WHEN IT REACHES HALF THE HEIGHT OF THE DEVICE.

(R-18) ESTIMATED AT 115 LBS. PER CU. FT

(R-24) ESTIMATED AT 0.075 GALLONS PER SQUARE YARD OF ORIGINAL EMULSION OF TACK COAT (BEFORE DILUTION FOR APPLICATION) IN ACCORDANCE WITH SECTION 407 OF THE STANDARD SPECIFICATIONS.

(R-25) ESTIMATED AT 112 LBS. PER SQ. YD. PER 1" THICK.

(R-32) PRICE BID TO INCLUDE COST OF 28-6" BARRIER CURB HOODS.

(R-33) THE PRECAST CONCRETE OPTION MAY BE USED INSTEAD, PER DIRECTION OF THE ENGINEER.

(R-38) TO BECOME THE PROPERTY OF AND BE DISPOSED OF BY THE CONTRACTOR IN A MANNER APPROVED BY THE ENGINEER.

(R-39) MATERIALS REMOVED SHALL NOT BE MEASURED FOR PAYMENT UNDER SECTION 202.06 UNCLASSIFIED EXCAVATION.

(1) INCLUDES APPROXIMATELY 3953 CY OF WASTE MATERIAL TO BE REMOVED FROM THE PROJECT TO A LOCATION APPROVED BY THE ENGINEER.

(2) ALL COST FOR REMOVING TREES, SHRUBS, STUMPS, POSTS, AND ALL OTHER DEBRIS AND/OR OBSTRUCTIONS NOT COVERED BY A SEPARATE PAY ITEM ARE INCLUDED IN THIS PRICE BID.

PAY QUANTITIES					
0100 ROADWAY					
ITEM		ITEM DESCRIPTION		UNIT	QUANTITY
201(A)	1200	CLEARING AND GRUBBING	(2)	LSUM	1
202(A)	2200	UNCLASSIFIED EXCAVATION	(R-1)(1)	CY	2787
205(A)	6200	TYPE A-SALVAGED TOPSOIL	(R-4)	LSUM	1
221(B)	2300	TEMPORARY SILT FENCE	(R-8)	LF	995
221(C)	2400	TEMPORARY SEDIMENT FILTER	(R-8)	EA	6
230(A)	7200	SOLID SLAB SODDING	(R-6)(R-7)	SY	1579
303(A)	1200	AGGREGATE BASE TYPE A		CY	631
310(B)	5300	SUBGRADE, METHOD B		SY	3399
325	0100	SEPARATOR FABRIC		SY	3957
407(B)	7300	TACK COAT	(R-24)	GAL	163
411(B)	1330	SUPERPAVE, TYPE S3 (PG 64-22 OK)	(R-25)	TON	605
411(C)	1430	SUPERPAVE, TYPE S4 (PG 64-22 OK)	(R-25)	TON	303
609(B)	4310	COMBINED CURB & GUTTER(6" BARRIER)		LF	1910
610(A)	5200	4" CONCRETE SIDEWALK		SY	978
610(B)	5310	6" CONCRETE DRIVEWAY		SY	369
610(I)	6000	TACTILE WARNING DEVICE-NEW		SF	60
611(A)	7210	MANHOLE (4' DIA.)	(R-33)	EA	3
611(G)	0268	INLET W/SMALL JCT. BOX, CI DES. 2(B)	(R-32)(R-33)	EA	1
611(G)	0276	INLET W/SMALL JCT. BOX, CI DES. 2(D)	(R-32)(R-33)	EA	2
611(G)	7790	INLET CI DES. 3(B)	(R-32)(R-33)	EA	3
611(H)	5330	ADD'L DEPTH IN INLET CI DES. 3	(R-33)	VF	5
611(H)	5970	ADD'L DEPTH IN INLET W/SJB CI DES. 2	(R-33)	VF	7
612(E)	3600	VALVE BOXES ADJUST TO GRADE		EA	4
613(E)	5964	(SP) 15" CORRUGATED POLYPROPYLENE PIPE	(R-1)	LF	460
613(E)	5968	(SP) 18" CORRUGATED POLYPROPYLENE PIPE	(R-1)	LF	126
619(A)	6200	REMOVAL OF STRUCTURES & OBSTRUCTIONS	(R-37)(R-38)	LSUM	1
619(B)	6352	REMOVAL OF FENCE	(R-38)	LF	107
619(B)	6356	REMOVAL OF CURB AND GUTTER	(R-38)(R-39)	LF	119
619(B)	6364	REMOVAL OF ASPHALT PAVEMENT	(R-38)(R-39)	SY	1716
619(B)	6380	REMOVAL OF CONCRETE DRIVEWAY	(R-38)(R-39)	SY	357
619(C)	6600	SAWING PAVEMENT		LF	153
624(E)	3610	FENCE-STYLE CLF (5' HIGH, CLASS A)	(R-41)	LF	107
629(D)	7500	REMOVE AND RESET MAILBOX		EA	11
641	2110	MOBILIZATION		LSUM	1
642(B)	3300	CONSTRUCTION STAKING LEVEL II		LSUM	1
880(J)	7110	CONSTRUCTION TRAFFIC CONTROL		LSUM	1

DESIGN	DGR	5/22	OKLAHOMA DEPARTMENT OF TRANSPORTATION				
DRAWN	TSS	5/22					
CHECKED	DGR	5/22					
APPROVED	XXX	XX/XX					
SQUAD							
COUNTY	CREEK	STREET	MAYFIELD ST	STATE JOB NO.	N/A	SHEET NO.	2

PAY ITEMS & NOTES

Groundwork Quantities - Mayfield St									
Station	Cut Area (Sq.ft.)	Cut Volume (Cu.yd.)	Reusable Volume (Cu.yd.)	Fill Area (Sq.ft.)	Fill Volume (Cu.yd.)	Cum. Cut Vol. (Cu.yd.)	Cum. Reusable Vol. (Cu.yd.)	Cum. Fill Vol. (Cu.yd.)	Cum. Net Vol. (Cu.yd.)
200+50.000	140.58	0	0	0.1	0	0	0	0	0
201+00.000	88.73	212.33	212.33	0.04	0.15	212.33	212.33	0.15	212.18
201+50.000	89.11	164.67	164.67	0.49	0.56	377	377	0.72	376.29
202+00.000	64.52	142.25	142.25	2.48	3.16	519.26	519.26	3.88	515.38
202+50.000	44.23	100.7	100.7	8.27	11.45	619.95	619.95	15.32	604.63
203+00.000	42.73	80.52	80.52	6.08	15.28	700.47	700.47	30.6	669.87
203+33.641	126.21	105.25	105.25	5.4	8.22	805.72	805.72	38.83	766.89
203+50.000	90.7	65.71	65.71	2.35	2.7	871.43	871.43	41.52	829.9
204+00.000	59.45	139.03	139.03	2.74	5.42	1010.46	1010.46	46.94	963.52
204+50.000	65.86	115.93	115.93	1.36	4.38	1126.38	1126.38	51.32	1075.06
205+00.000	62.92	119.25	119.25	6.05	7.89	1245.63	1245.63	59.21	1186.42
205+19.817	55.32	43.39	43.39	16.97	9.72	1289.02	1289.02	68.93	1220.09
205+50.000	47.84	57.66	57.66	7.29	15.6	1346.68	1346.68	84.53	1262.15
206+00.000	46.98	87.79	87.79	9.65	18.04	1434.47	1434.47	102.57	1331.9
206+50.000	41.93	82.32	82.32	12.08	23.14	1516.79	1516.79	125.71	1391.08
206+59.698	44.1	15.45	15.45	4.79	3.48	1532.24	1532.24	129.19	1403.05
206+59.940	44.13	0.4	0.4	4.67	0.05	1532.64	1532.64	129.24	1403.39
207+00.000	51.63	71.04	71.04	1.56	5.31	1603.67	1603.67	134.56	1469.12
207+50.000	77.03	119.13	119.13	0.93	2.65	1722.8	1722.8	137.21	1585.59
207+57.583	74.21	21.24	21.24	0.83	0.28	1744.04	1744.04	137.49	1606.55
208+00.000	63.96	108.53	108.53	9.12	8.99	1852.57	1852.57	146.48	1706.09
208+12.116	92.79	35.17	35.17	5.68	3.82	1887.74	1887.74	150.3	1737.44
208+50.000	109.91	142.2	142.2	5.93	9.36	2029.94	2029.94	159.66	1870.28
209+00.000	141.02	232.34	232.34	0	6.31	2262.28	2262.28	165.97	2096.31
209+50.000	131.46	252.3	252.3	0.02	0.02	2514.57	2514.57	165.99	2348.59
210+00.000	81.24	196.94	196.94	0	0.02	2711.52	2711.52	166.01	2545.51
210+50.000	0	75.22	75.22	0	0	2786.74	2786.74	166.01	2620.73

SUMMARY OF DRIVEWAYS						
STATION	SIDE	RADIUS	WIDTH	LENGTH	6" CONCRETE DRIVEWAY	6" AGGREGATE BASE TYPE A
		FT	FT	FT	SY	CY
205+19.82	RT	5	27	31	94	16
206+59.70	RT	5	22	21	51	9
206+59.81	LT	5	13	22	32	6
207+57.58	LT	5	45	26	131	22
208+12.12	LT	5	21	26	61	11

STATIONS	SUMMARY OF REMOVAL							
	REMOVAL OF DRIVEWAY	REMOVAL OF ASPHALT PAVEMENT (FULL DEPTH)	REMOVAL OF CURB & GUTTER	REMOVAL OF FENCE	REMOVE AND RESET MAILBOX	REMOVAL OF TREE (18" TO 24" IN DIAMETER)	REMOVAL OF TREE (25" & MORE IN DIAMETER)	SAVING PAVEMENT
	SY	SY	LF	LF	EA	EA	EA	LF
200+00 TO 204+00	34	754	119	64	1	2	0	74
204+00 TO 208+00	277	631	0	0	8	0	0	33
208+00 TO 210+55	46	331	0	43	2	0	1	46
TOTALS	357	1716	119	107	11	2	1	153

SUMMARY OF ROADWAY														
STATIONS	FULL DEPTH						COMBINED CURB & GUTTER (6" BARRIER)	DRIVEWAY	DRIVEWAY			TACTILE WARNING DEVICE	FENCE-STYLE CLF (5' HIGH)	SOLID SLAB SODDING
	8" STABILIZED SUBGRADE	SEPARATOR FABRIC	6" AGGREGATE BASE TYPE A	4" SUPERPAVE. TYPE S3 (PG 64-22 OK)	2" SUPERPAVE. TYPE S4 (PG 64-22 OK)	TACK COAT			6" CONCRETE DRIVEWAY	6" AGGREGATE BASE TYPE A	4" CONCRETE SIDEWALK			
	SY	SY	CY	TON	TON	GAL			LF	CY	SY			
200+00 TO 204+00	1346	1554	225	243	122	65	754	0	0	0	354	40	64	457
204+00 TO 208+00	1305	1527	218	230	115	62	719	52	308	52	386	0	0	839
208+00 TO 210+55	748	876	125	132	66	36	437	11	61	11	238	20	43	489
TOTALS	3399	3957	568	605	303	163	1910	63	369	63	978	60	107	1785

ADJUST TO GRADE TABLE			
STATION	OFFSET	SIDE	WATER VALVE
200+56.38	36.70	LT	1
203+12.47	32.45	LT	1
203+15.14	34.81	LT	1
205+83.39	19.26	LT	1
TOTAL			4

DESIGN	DGR	5/22	OKLAHOMA DEPARTMENT OF TRANSPORTATION	
DRAWN	TSS	5/22		
CHECKED	DGR	5/22		
APPROVED	XXX	XX/XX		
SQUAD				
COUNTY	CREEK	STREET		MAYFIELD ST
STATE JOB NO.		N/A	SHEET NO.	3

SUMMARY SHEET

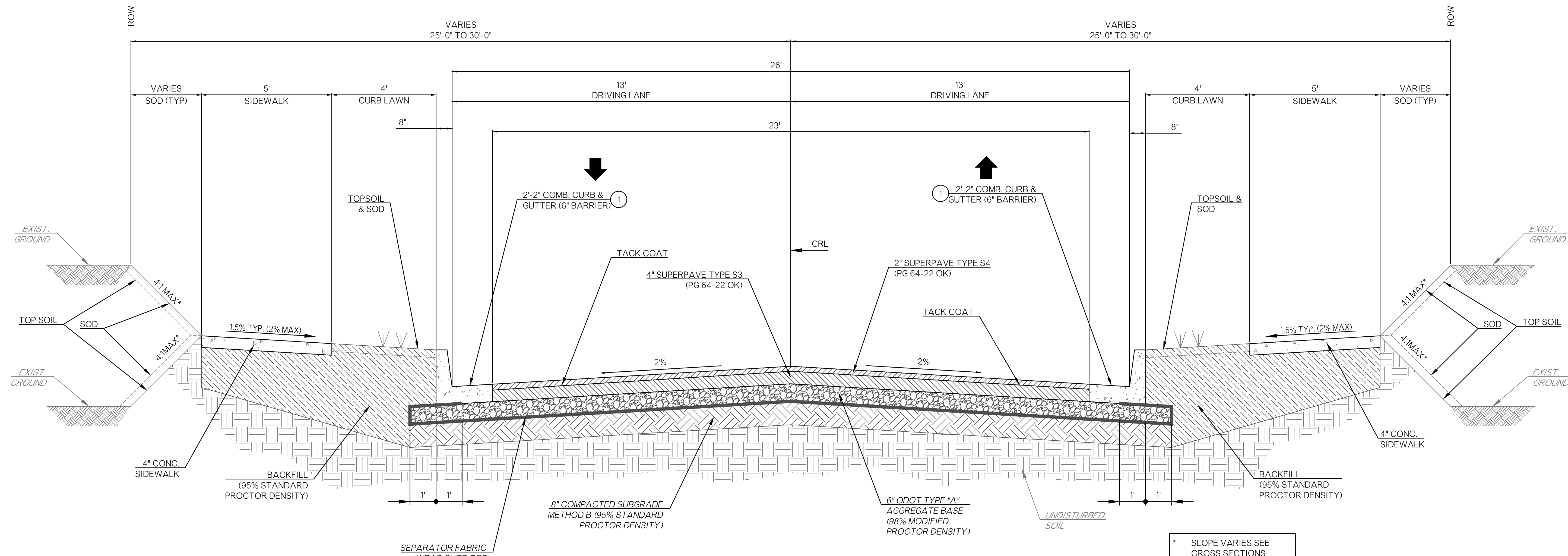

N.T.S.  
**23' RESIDENTIAL COLLECTOR**  
**FULL DEPTH TYPICAL SECTION**  
 200+47.07 TO 210+11.68 (E MAYFIELD ST)

\* SLOPE VARIES SEE CROSS SECTIONS

DESIGN	DGR	5/22	OKLAHOMA DEPARTMENT OF TRANSPORTATION
DRAWN	TSS	5/22	
CHECKED	DGR	5/22	
APPROVED	XXX	XX/XX	
SQUAD	<b>ILCE</b>		
COUNTY	CREEK	STREET	MAYFIELD ST
		STATE JOB NO.	N/A
		SHEET NO.	4

TYPICAL SECTIONS

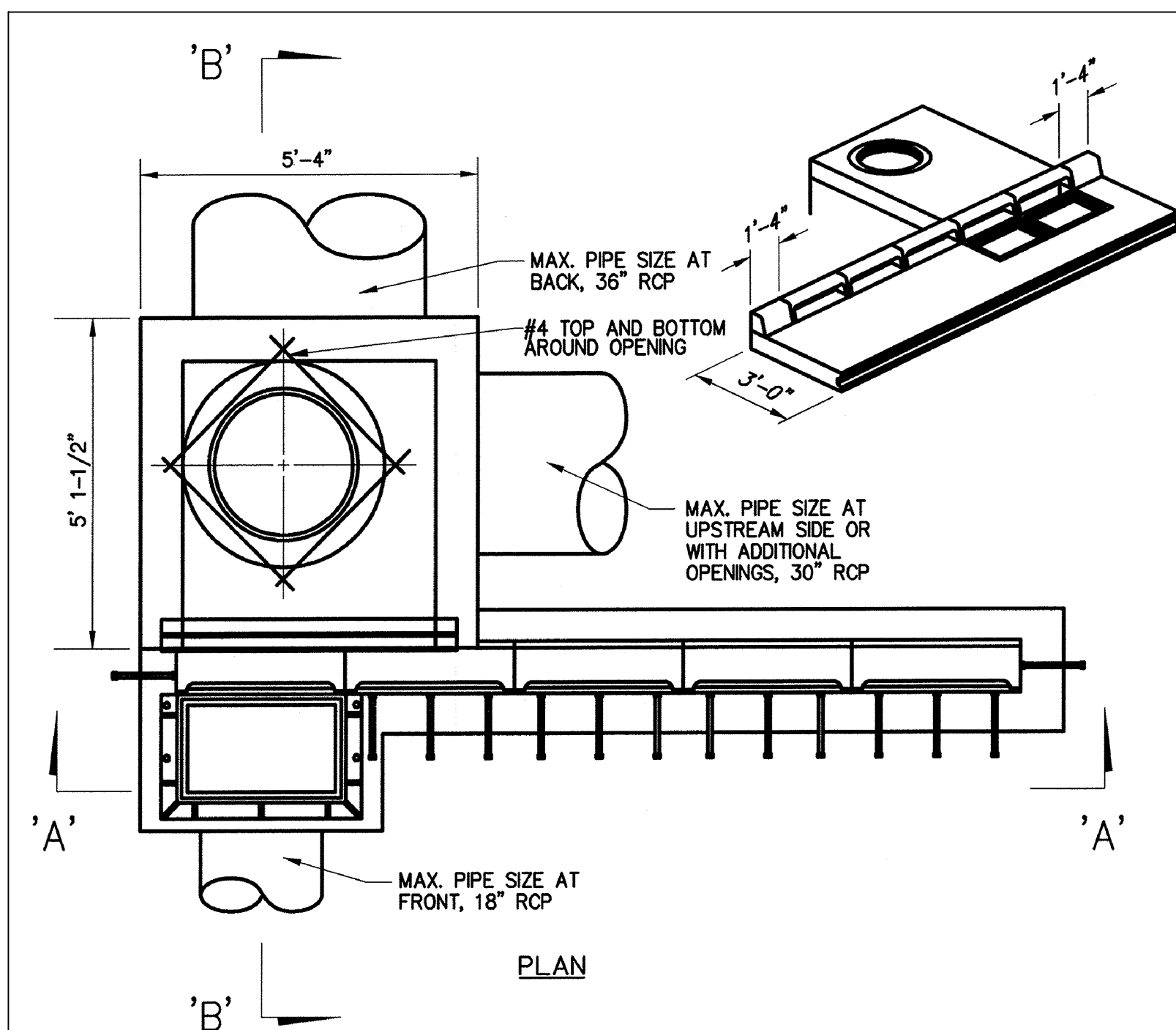

QUANTITIES FOR INLETS							
INLET	CURB OPENING	CLASS "A" CONCRETE	INLET	INLET FRAME AND GRATE	CAST IRON CURB INLET	MH FRAME AND COVER	
DESIGN	DESIGNATION	CU. YD.	BASE AM T.	ADD'L. C.F. PER VERT. FT.	EACH	EACH	EACH
1 WITH SMALL JUNCT. BOX	"A"	1.50	43.56	15.84	1	1	1
	"B"	1.60	47.34	17.43	1	2	1
	"C"	1.73	55.44	21.03	1	3	1
	"D"	1.86	62.26	24.63	1	4	1
2 WITH SMALL JUNCT. BOX	"A"	1.70	47.84	17.40	2	2	1
	"B"	1.83	57.01	21.00	2	3	1
	"C"	1.96	64.86	24.60	2	4	1
	"D"	2.08	71.70	28.20	2	5	1
1 WITH LARGE JUNCT. BOX	"A"	2.11	50.44	18.34	1	1	1
	"B"	2.21	54.22	19.93	1	2	1
	"C"	2.34	62.32	23.53	1	3	1
	"D"	2.47	69.14	27.13	1	4	1
2 WITH LARGE JUNCT. BOX	"A"	2.60	74.91	30.73	1	5	1
	"B"	2.31	54.72	19.90	2	2	1
	"C"	2.43	63.89	23.50	2	3	1
	"D"	2.57	71.74	27.10	2	4	1
1 WITH LARGE JUNCT. BOX	"A"	2.69	78.58	30.70	2	5	1
	"B"	2.82	84.16	34.30	2	6	1
	"C"						
	"D"						

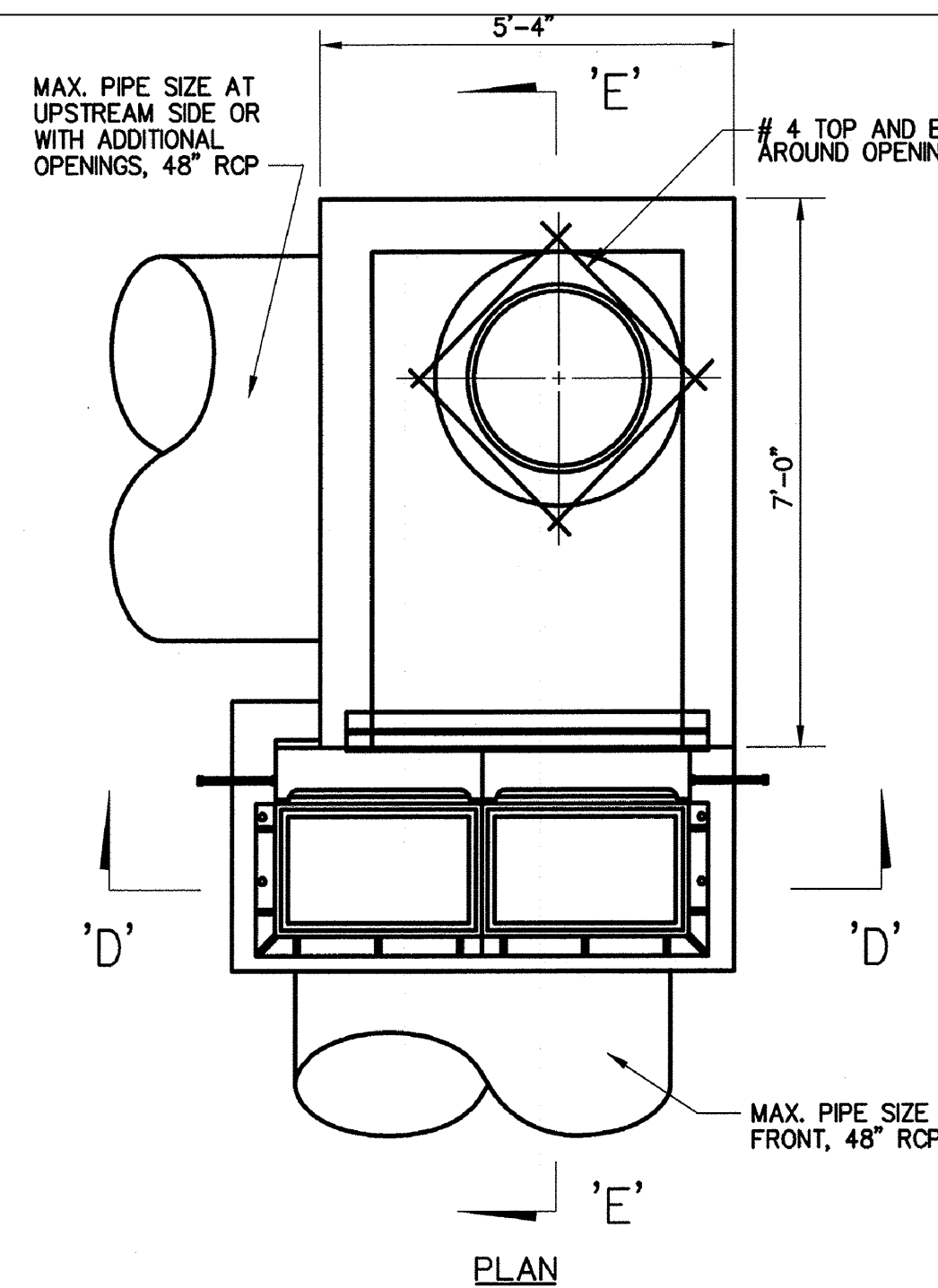

- NOTES:**
- (a) WHEN THE INLET IS BUILT IN EXISTING PAVEMENT, THE APRON AROUND THE INLET SHALL BE OF THE SIZE SHOWN IN THE PLAN ON THIS SHEET, AND BUILT OF P.C. CONCRETE TO A MINIMUM 8" THICKNESS.
  - (b) THERE WILL BE NO DEDUCTION OF PAYMENT FOR CONCRETE CURB AND GUTTER FOR THE LENGTH OR AREA OCCUPIED BY THE CONSTRUCTION OF CAST IRON CURB INLETS OR CAST IRON CURB INLET FRAME AND GRATE.
  - RUBBER COATED REINFORCED STEEL STEPS SHALL BE PLACED AT THE HEADERS IN ALL INLETS 4' OR MORE IN DEPTH. COST OF STEPS SHALL BE INCLUDED IN THE PRICE BID FOR INLET.
  - GRATING AND FRAMES TO BE USED IN THIS INLET ARE SHOWN ON THE STANDARD DRAWINGS STD 765, STD 766, DESIGNATED AS "STANDARD STORM SEWER GRATES AND FRAMES."
  - THE STANDARD DRAWING DESIGNATION NO., DESIGN NO., AND NUMBER OF ADDITIONAL OPENINGS SHALL BE INDICATED ON THE PLANS.
  - COST OF STRUCTURAL STEEL I-BEAMS AND ANGLE IRON TO BE INCLUDED IN THE PRICE BID FOR INLET. ANGLE IRON SHALL CONFORM TO ASTM-A7 OR A36.
  - CASTING SHALL CONFORM TO ASTM SPECIFICATION FOR GREY IRON CASTINGS, SERIAL DESIGNATION A-48-CLASS 20.
  - NO WORDING OR MARKING OF ANY KIND OTHER THAN THOSE SHOWN ON THE PLANS WILL BE PERMITTED ON THESE CASTINGS.
  - ALL NUTS AND BOLTS REQUIRED FOR THESE STRUCTURES SHALL BE CADMIUM PLATED OR GALVANIZED.
  - CAST IRON CURBS TO BE USED ON THIS INLET ARE SHOWN ON STANDARD DRAWING DESIGNATED AS "STANDARD CAST IRON CURB."
  - ALL MORTAR JOINTS TO BE 3/8" MAXIMUM, EVERY FIFTH COURSE OF BRICK MASONRY TO BE HEADER COURSE.
  - CURB INLETS SHALL BE PLACED ON UPSTREAM SIDE OF GRATE INLETS FOR TYPICAL INSTALLATIONS.
  - CONCRETE TROUGH FOR CURB INLETS AND STORM SEWER INLETS SHALL BE CONSTRUCTED AS ONE UNIT.
  - IF PRECAST INLET IS USED, FLOWABLE FILL MUST BE USED AS BACKFILL AROUND THE ENTIRE INLET.
  - USE MANHOLE FRAME AND LID AS SHOWN ON STANDARD DRAWING NO. 754
  - MANHOLE FRAME AND LID MUST BE FLUSH WITH TOP OF THE SURROUNDING CONCRETE SLAB.
- \* BASES TO BE FORMED WITH 1 X 6 FORMS AND POURED IN PLACE.

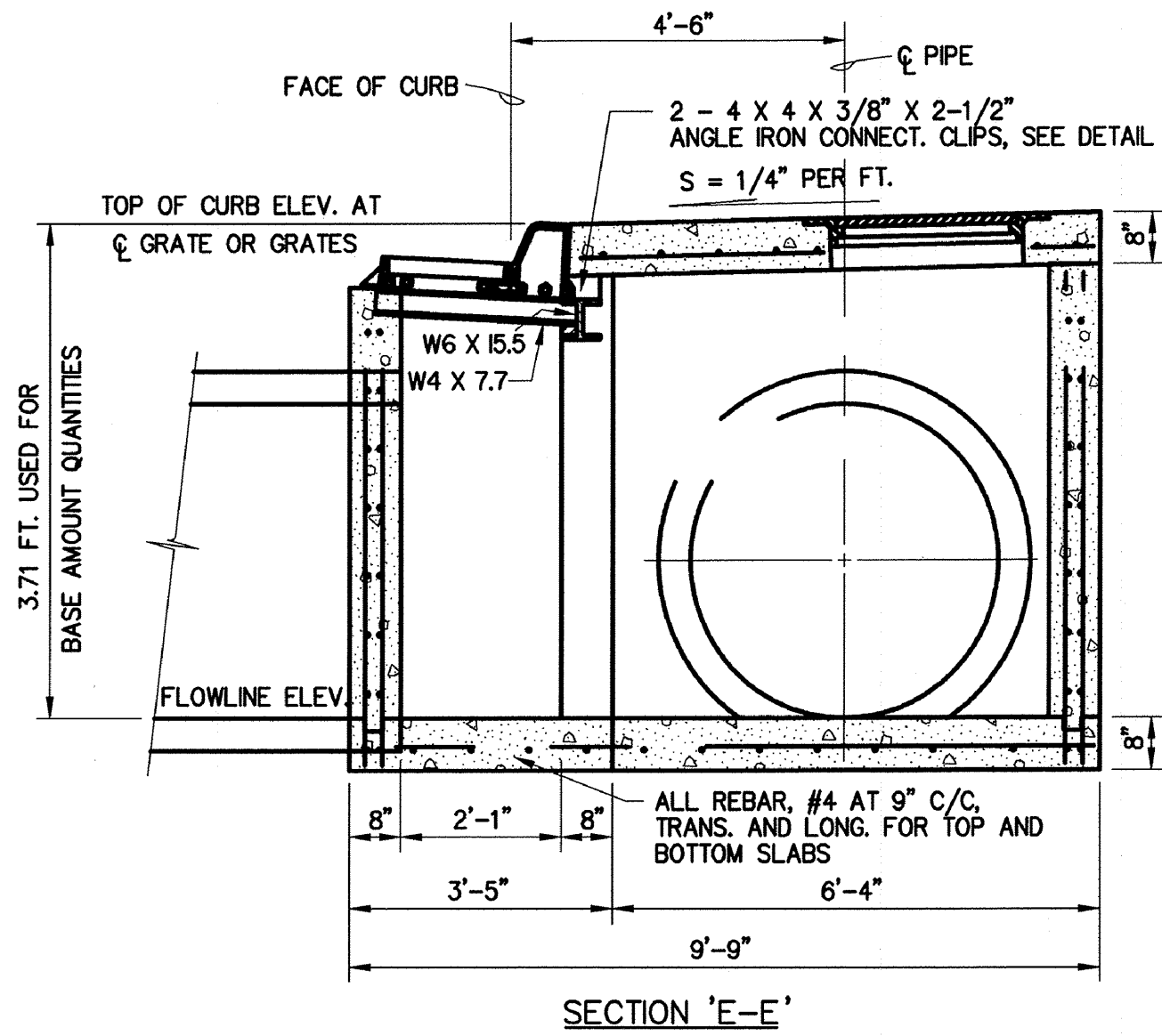
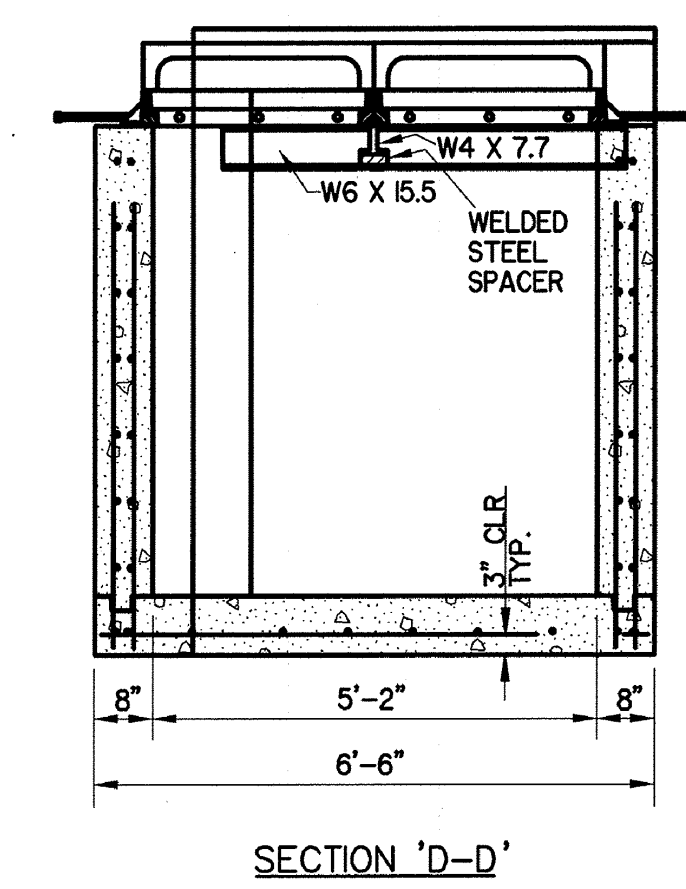
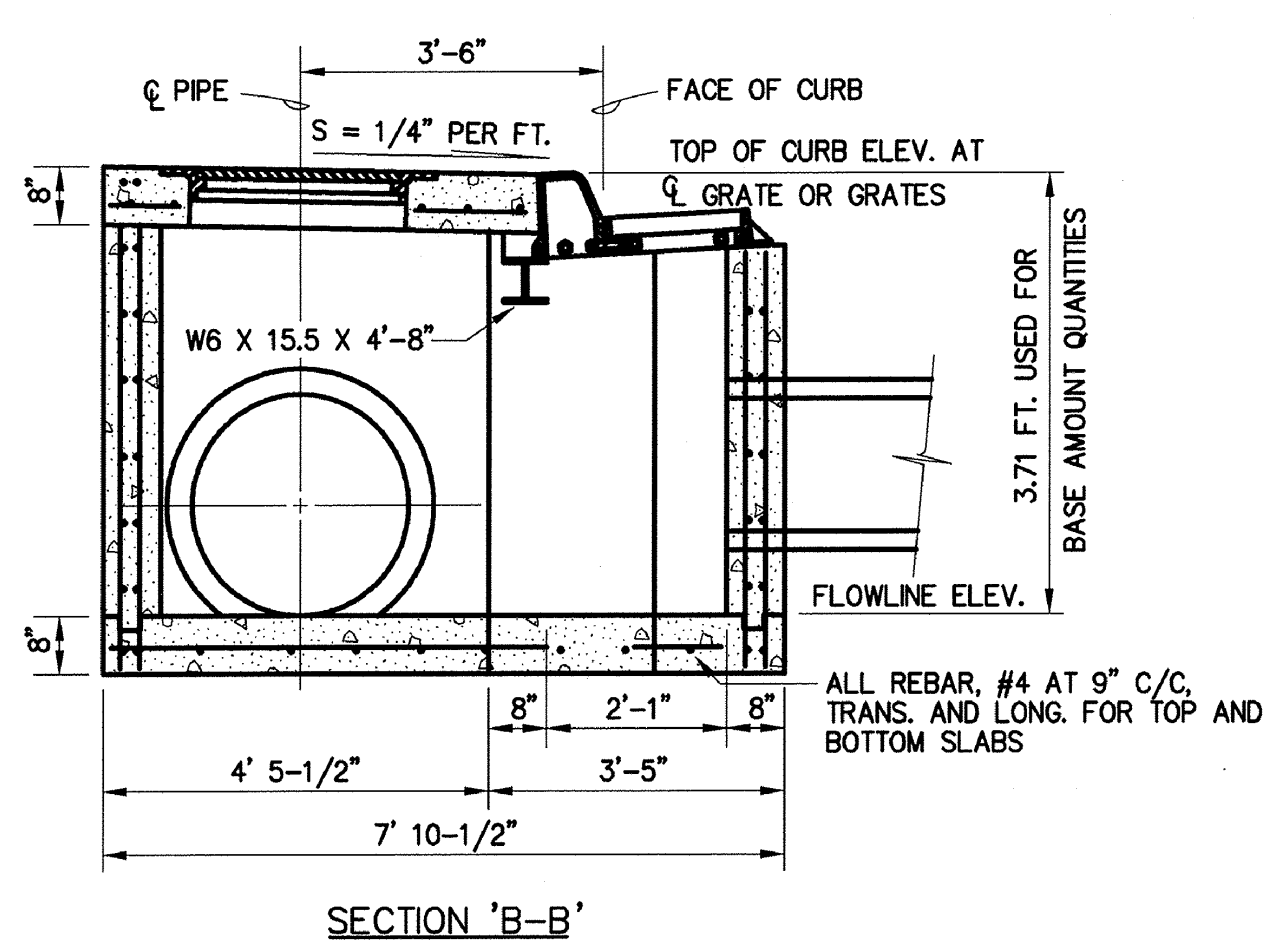
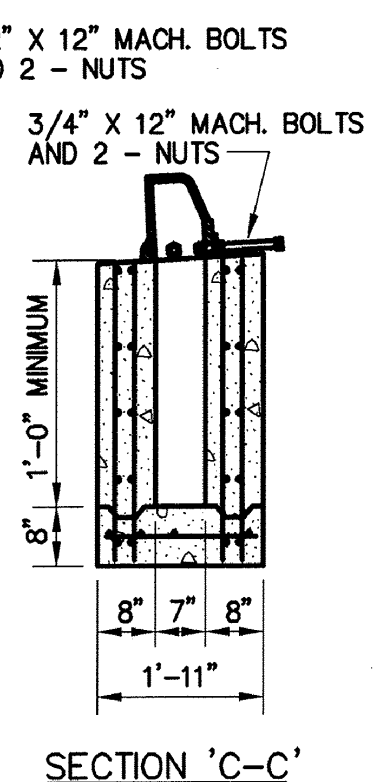
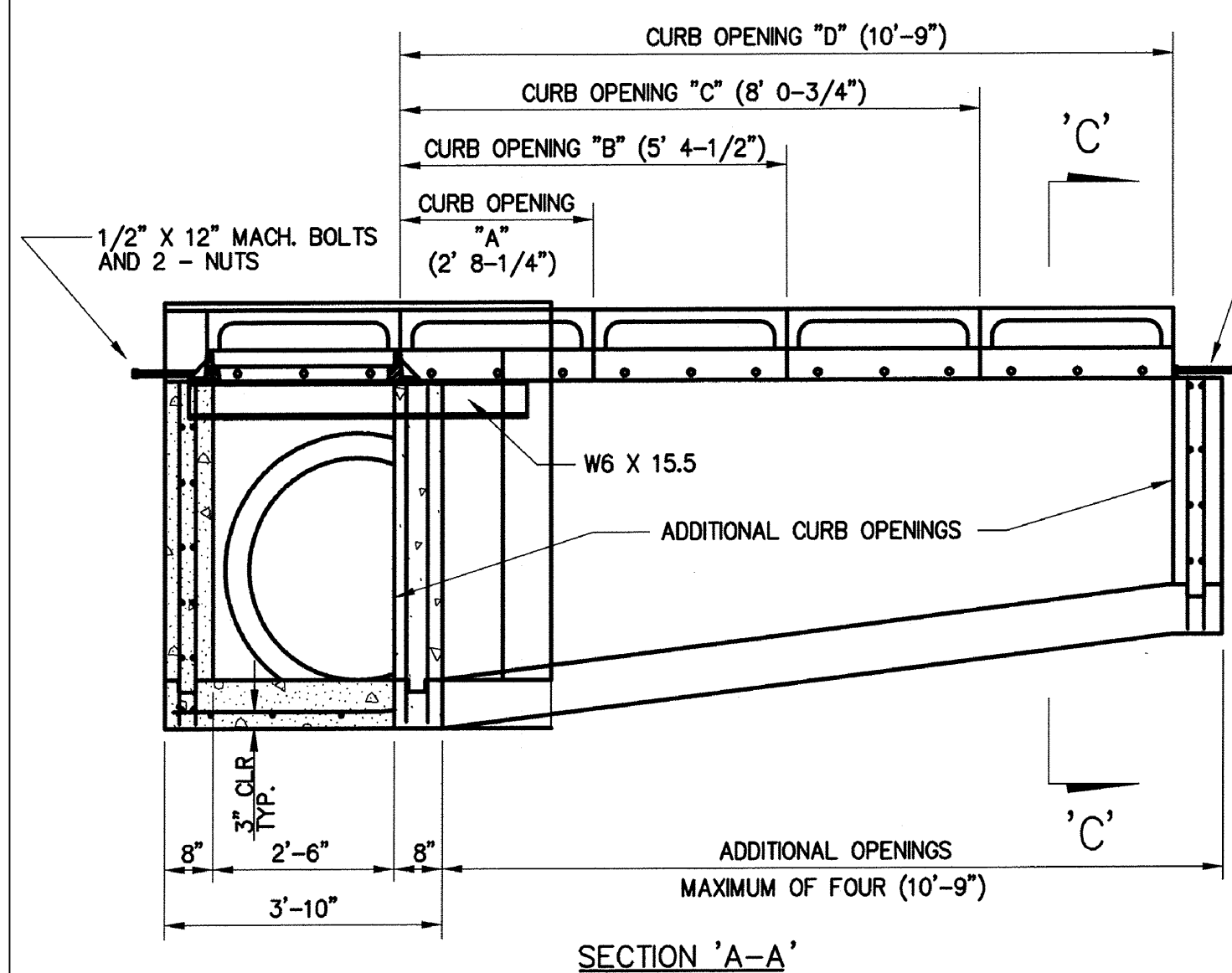

**SINGLE GRATE CURB INLET WITH JUNCTION BOX**  
(DESIGN 1-D WITH SMALL JUNCTION BOX SHOWN)

ALL REBAR IN WALLS #4 @ 12" CTRS EA WAY (TYPICAL)

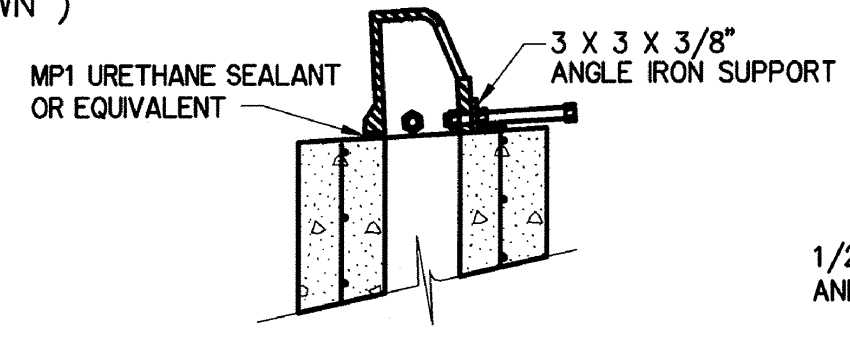

**ADDITIONAL CURB OPENING DETAILS**

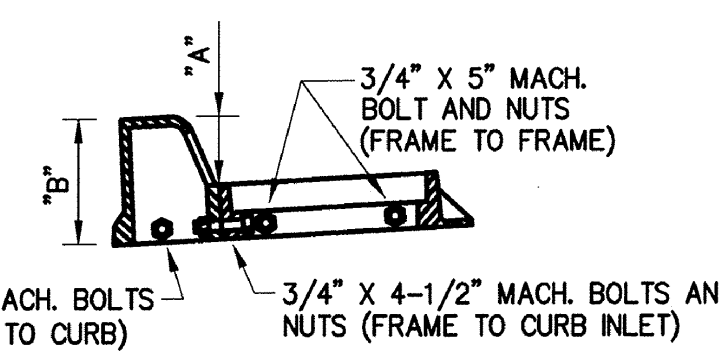

**FRAME AND CURB DETAILS**

$D' = \text{SUMP DEPTH} + 1'-8"$   
 $D'' = \text{CROSS SLOPE} \times 1.67' + 0.04$

**DOUBLE GRATE CURB INLET WITH JUNCTION BOX**

(DESIGN 2 WITH LARGE JUNCTION BOX SHOWN)  
18" THRU 30" LONGITUDINAL PIPE REQUIRES SMALL JUNCTION BOX  
ALL REBAR IN WALLS #4 @ 12" CTRS EA WAY (TYPICAL)

BASIS OF PAYMENT		
ITEM NO.	ITEM	UNIT
6 11.06 (E)	INLET	EA.
6 11.06 (F)	ADDITIONAL DEPTH IN INLET	VERT. FT.
6 11.06 (G)	INLET FRAME AND GRATE	EA.
6 11.06 (D)	MANHOLE FRAME AND COVER	EA.
6 11.06 (K)	CAST IRON CURB INLETS	EA.

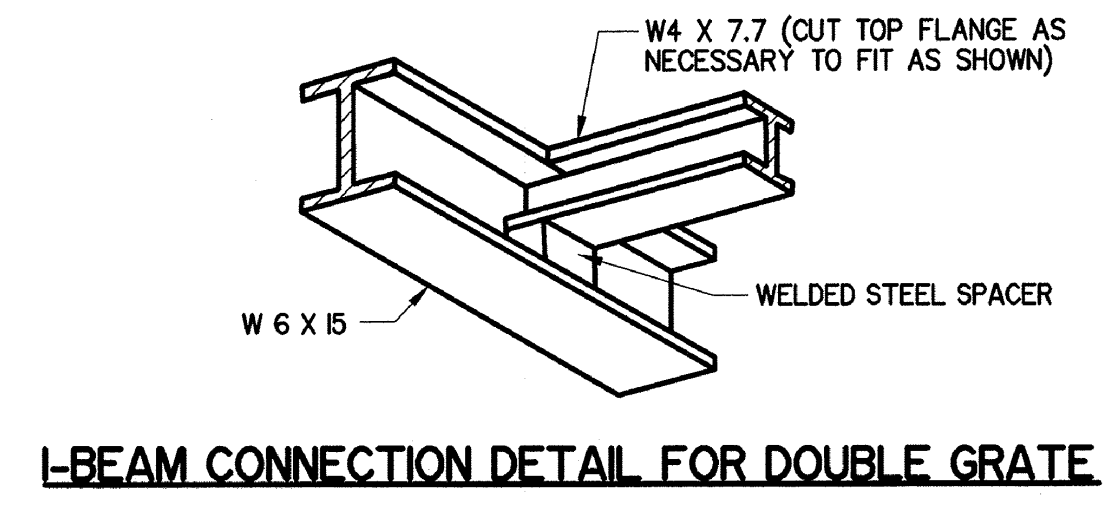

**I-BEAM CONNECTION DETAIL FOR DOUBLE GRATE**

ANGLE IRON LENGTHS	
OPENING	LENGTH
"A"	2' 5-3/8"
"B"	5' 1-5/8"
"C"	7' 9-7/8"
"D"	10' 6-1/8"

C.I. CURB HEIGHTS		
TYPE	"A"	"B"
4" MOUNTABLE	4-1/2"	9-1/2"
6" MOUNTABLE	6-1/2"	11-1/2"
6" BARRIER	6-1/2"	11-1/2"
8" BARRIER	8-1/2"	13-1/2"

# STORMWATER POLLUTION PREVENTION PLAN

## SITE DESCRIPTION

PROJECT LIMITS: MAYFIELD STREET FROM EAST THOMPSON AVENUE TO EAST DEWEY AVENUE.

PROJECT DESCRIPTION: STREET IMPROVEMENTS OF MAYFIELD INCLUDING WIDENING, SIDEWALK IMPROVEMENTS TO ADA COMPLIANCE AND STORMWATER IMPROVEMENTS THROUGHOUT PROJECT.

**SUGGESTED SEQUENCE OF EROSION CONTROL ACTIVITIES:**

1. INSTALL ALL TEMPORARY EROSIONS CONTROL MEASURES & SILT FENCE. INSTALL SEDIMENTATION PROTECTION AROUND ALL EXISTING DRAINAGE INLETS.
2. SET TRAFFIC CONTROL DEVICES TO DIVERT THRU TRAFFIC.
3. CONSTRUCT PAVEMENT AND STORMWATER IMPROVEMENTS AS SHOWN ON PLANS.
4. REMOVE ALL TEMPORARY EROSION CONTROL MEASURES. MAINTAIN EROSION CONTROL MEASURES AROUND INLETS UNTIL PROJECT COMPLETION & ACCEPTANCE BY OWNER.
5. INSTALL PERMANENT EROSION CONTROL (SOLID SLAB SOD) AROUND ALL DISTURBED AREAS OR WHERE REQUIRED.

SOIL TYPE: BIGHEART-NIOTAZE-ROCK OUTCROP COMPLEX (1 TO 8 PERCENT SLOPES), NIOTAZE-BIGHEART-ROCK OUTCROP COMPLEX (3 TO 15 AND 25 TO 45 PERCENT SLOPES)

TOTAL AREA OF THE CONSTRUCTION SITE: 1.50 ACRES

ESTIMATED AREA TO BE DISTURBED: 1.36 ACRES

OFFSITE AREA TO BE DISTURBED (FOR CONTRACTOR USE): N/A

TOTAL IMPERVIOUS AREA PRE-CONSTRUCTION: 0.45 ACRES

TOTAL IMPERVIOUS AREA POST-CONSTRUCTION: 0.90 ACRES

POST-CONSTRUCTION RUNOFF COEFFICIENT OF THE SITE: 0.45

LATITUDE & LONGITUDE OF CENTER OF PROJECT: 35.9979669° N, 96.0881935° W

**PROJECT WILL DISCHARGE TO:**

NAME OF RECEIVING WATERS: POLECAT CREEK

SENSITIVE WATERS OR WATERSHEDS: YES  NO

303 (d) IMPAIRED WATERS: YES  NO

IF YES, LIST IMPAIRMENT: ENTEROCOCCUS, ESCHERICHIA COLI

LOCATED IN A TMDL: YES  NO

LAKE THUNDERBIRD TMDL: YES  NO

MS4 ENTITY YES  NO

IF YES, LOCATION: CITY OF SAPULPA

HISTORICAL PROPERTIES N/A

NOTE:  
THIS SHEET SHOULD BE USED IN CONJUNCTION WITH A DRAINAGE MAP THAT ILLUSTRATES THE DRAINAGE PATTERNS/PATHWAYS AND RECEIVING WATERS FOR THIS PROJECT. THIS SHEET SHOULD ALSO BE USED WITH THE EROSION CONTROL SUMMARIES, PAY ITEMS, & NOTES.

## EROSION AND SEDIMENT CONTROLS

**SOIL STABILIZATION PRACTICES:**

- TEMPORARY SEEDING
- PERMANENT SODDING, SPRIGGING OR SEEDING
- VEGETATIVE MULCHING
- SOIL RETENTION BLANKET
- PRESERVATION OF EXISTING VEGETATION

NOTE: TEMPORARY EROSION CONTROL METHODS MUST BE USED ON ALL DISTURBED AREAS WHERE CONSTRUCTION ACTIVITIES HAVE CEASED FOR OVER 14 DAYS. METHODS USED WILL BE AS SHOWN ON PLANS, OR AS DIRECTED BY THE ENGINEER.

**STRUCTURAL PRACTICES:**

- STABILIZED CONSTRUCTION EXIT
- TEMPORARY SILT FENCE
- TEMPORARY SILT DIKES
- TEMPORARY FIBER LOG
- DIVERSION, INTERCEPTOR OR PERIMETER DIKES
- DIVERSION, INTERCEPTOR OR PERIMETER SWALES
- ROCK FILTER DAMS
- TEMPORARY SLOPE DRAIN
- PAVED DITCH W/ DITCH LINER PROTECTION
- TEMPORARY DIVERSION CHANNELS
- TEMPORARY SEDIMENT BASINS
- TEMPORARY SEDIMENT TRAPS
- TEMPORARY SEDIMENT FILTERS
- TEMPORARY SEDIMENT REMOVAL
- RIP RAP
- INLET SEDIMENT FILTER
- TEMPORARY BRUSH SEDIMENT BARRIERS
- SANDBAG BERMS
- TEMPORARY STREAM CROSSINGS

**OFFSITE VEHICLE TRACKING:**

- HAUL ROADS DAMPENED FOR DUST CONTROL
- LOADED HAUL TRUCKS TO BE COVERED WITH TARPULIN
- EXCESS DIRT ON ROAD REMOVED DAILY

**NOTES:**

CONTRACTOR RESPONSIBLE FOR MAINTAINING EROSION/SEDIMENTATION CONTROLS (BMPS) FOR THE DURATION OF THE PROJECT.

THE CONTRACTOR SHALL ALSO BE RESPONSIBLE FOR THE FOLLOWING:

**MAINTENANCE AND INSPECTION:**

ALL EROSION AND SEDIMENT CONTROLS WILL BE MAINTAINED IN GOOD WORKING ORDER FROM THE BEGINNING OF CONSTRUCTION UNTIL AN ACCEPTABLE VEGETATIVE COVER IS ESTABLISHED. INSPECTION BY THE CONTRACTOR AND ANY NECESSARY REPAIRS SHALL BE PERFORMED ONCE EVERY 7 CALENDAR DAYS AND WITHIN 24 HOURS AFTER ANY STORM EVENT GREATER THAN 0.5 INCH AS RECORDED BY A NON-FREEZING RAIN GAUGE TO BE LOCATED ON SITE. POTENTIALLY ERODIBLE AREAS, DRAINAGEWAYS, MATERIAL STORAGE, STRUCTURAL DEVICES, CONSTRUCTION ENTRANCES AND EXITS ALONG WITH EROSION AND SEDIMENT CONTROL LOCATIONS ARE EXAMPLES OF SITES THAT NEED TO BE INSPECTED.

**WASTE MATERIALS:**

PROPER MANAGEMENT AND DISPOSAL OF CONSTRUCTION WASTE MATERIAL IS REQUIRED BY THE CONTRACTOR. MATERIALS INCLUDE STOCKPILES, SURPLUS, DEBRIS AND ALL OTHER BY-PRODUCTS FROM THE CONSTRUCTION PROCESS. PRACTICES INCLUDE DISPOSAL, PROPER MATERIALS HANDLING, SPILL PREVENTION AND CLEANUP MEASURES. CONTROLS AND PRACTICES SHALL MEET THE REQUIREMENTS OF ALL FEDERAL, STATE AND LOCAL AGENCIES.

**HAZARDOUS MATERIALS:**

PROPER MANAGEMENT AND DISPOSAL OF HAZARDOUS WASTE MATERIAL IS REQUIRED. THE CONTRACTOR IS RESPONSIBLE FOR FOLLOWING MANUFACTURER'S RECOMMENDATIONS, STATE AND FEDERAL REGULATIONS TO ENSURE CORRECT HANDLING, DISPOSAL, SPILL PREVENTION AND CLEANUP MEASURES. EXAMPLES INCLUDE BUT ARE NOT LIMITED TO: PAINTS, ACIDS, CLEANING SOLVENTS, CHEMICAL ADDITIVES, CONCRETE CURING COMPOUNDS AND CONTAMINATED SOILS.

**GENERAL NOTES:**

A STORM WATER POLLUTION PREVENTION PLAN (SWPPP) IS REQUIRED TO COMPLY WITH THE OKLAHOMA POLLUTION DISCHARGE ELIMINATION SYSTEM (OPDES) REGULATIONS. THIS PLAN IS INITIATED DURING THE DESIGN PHASE, CONFIRMED IN THE PRE-WORK MEETINGS AND AVAILABLE ON THE JOB SITE ALONG WITH COPIES OF THE NOTICE OF INTENT (NOI) FORM AND PERMIT CERTIFICATE THAT HAVE BEEN FILED WITH THE OKLAHOMA DEPARTMENT OF ENVIRONMENTAL QUALITY (ODEQ). THE PLAN MUST BE KEPT CURRENT WITH UP-TO-DATE AMENDMENTS DURING THE PROGRESSION OF THE PROJECT. ALL CONTRACTOR OFF-SITE OPERATIONS ASSOCIATED WITH THE PROJECT MUST BE DOCUMENTED IN THE SWPPP, I.E., BORROW PITS, WORK ROADS, DISPOSAL SITES, ASPHALT/CONCRETE PLANTS, ETC. THE BASIC GOAL OF STORM WATER MANAGEMENT IS TO IMPROVE WATER QUALITY BY REDUCING POLLUTANTS IN STORM WATER DISCHARGES. RUNOFF FROM CONSTRUCTION SITES HAS A POTENTIAL FOR POLLUTION DUE TO EXPOSED SOILS AND THE PRESENCE OF HAZARDOUS MATERIALS USED IN THE CONSTRUCTION PROCESS. THE PREVENTION OF SOIL EROSION, CONTAINMENT OF HAZARDOUS MATERIALS AND/OR THE INTERCEPTION OF THESE POLLUTANTS BEFORE LEAVING THE CONSTRUCTION SITE ARE THE BEST PRACTICES FOR CONTROLLING STORM WATER POLLUTION.

**THE FOLLOWING SECTIONS OF THE 2009 ODOT STANDARD SPECIFICATIONS SHOULD BE NOTED:**

103.05	BONDING REQUIREMENTS
104.10	FINAL CLEANING UP
104.12	CONTRACTOR'S RESPONSIBILITY FOR WORK
104.13	ENVIRONMENTAL PROTECTION
106.06	STORAGE AND HANDLING OF MATERIAL
107.01	LAWS, RULES AND REGULATIONS TO BE OBSERVED
107.20	STORM WATER MANAGEMENT
220	MANAGEMENT OF EROSION, SEDIMENTATION AND STORM WATER POLLUTION PREVENTION AND CONTROL
221	TEMPORARY SEDIMENT CONTROL

**IN ADDITION:**

"ODEQ GENERAL PERMIT (OKR10) FOR STORM WATER DISCHARGES FROM CONSTRUCTION ACTIVITIES WITHIN THE STATE OF OKLAHOMA." ODEQ, WATER QUALITY DIVISION, SEPTEMBER 13, 2017.

DESIGN	DGR	5/22	OKLAHOMA DEPARTMENT OF TRANSPORTATION  <b>STORMWATER POLLUTION PREVENTION PLAN</b>				
DRAWN	TSS	5/22					
CHECKED	DGR	5/22					
APPROVED	XXX	XX/XX					
SQUAD							
COUNTY	CREEK	STREET	DEWEY AVE	STATE JOB NO.	N/A	SHEET NO.	6

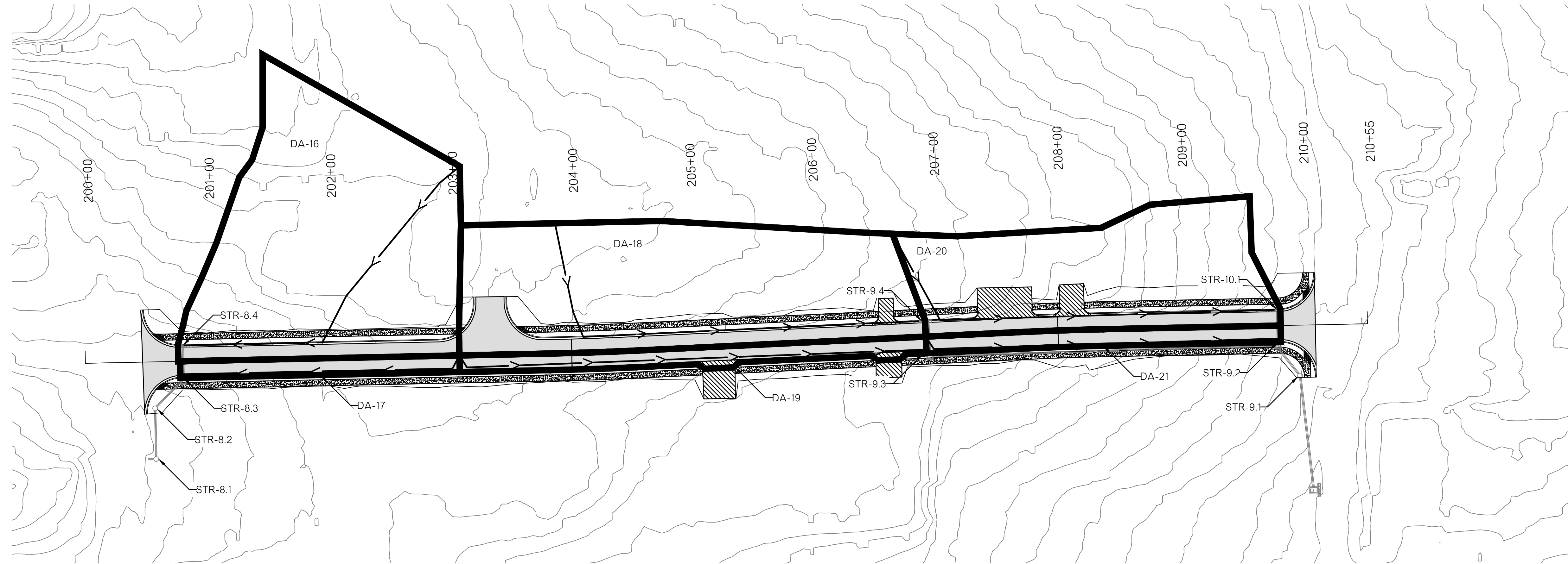

SUMMARY OF HYDROLOGIC DATA AND RUNOFF CALCULATIONS

D.A. NUMBER	INLET	C	Area (ACRES)	LAND USE/TYPE	OVERLAND LENGTH (FT)	SLOPE (%)	VELOCITY (FPS)	OVERLAND FLOW TIME (MIN)	UNPAVED OR PAVED	CHANNEL LENGTH (FT)	SLOPE (%)	VELOCITY (FPS)	CHANNEL FLOW TIME (MIN)	TIME OF CONCENTRATION (MIN)	INTENSITY 10-YR (IPH)	INTENSITY 100-YR (IPH)	Q 10-YR (CFS)	Q 100-YR (CFS)
16	8.4	0.50	0.93	G	150	3.00	1.25	2.00	P	150	3.85	3.95	0.63	2.63	8.26	12.08	3.83	5.60
17	8.3	0.90	0.07	P	13	2.00	2.70	0.08	P	224	3.85	3.95	0.94	1.03	8.91	13.04	0.58	0.85
18	9.4	0.50	0.85	G	150	3.33	1.32	1.90	P	276	2.87	3.37	1.37	3.26	8.03	11.75	3.43	5.02
19	9.3	0.90	0.13	P	13	2.00	2.70	0.08	P	378	2.87	3.37	1.87	1.95	8.52	12.47	0.96	1.41
20	10.1	0.50	0.60	G	81	3.33	1.32	1.03	P	278	8.36	5.93	0.78	1.81	8.58	12.55	2.57	3.76
21	9.2	0.90	0.09	P	13	2.00	2.70	0.08	P	286	8.36	5.93	0.80	0.88	8.97	13.13	0.74	1.08

STORM SEWER SUMMARY TABLE

STR. NO. UPSTREAM	STATION	OFFSET	SIDE	DESCRIPTION	DESIGN	MANHOLE (4' DIA.)	INLET W/ SMALL I.C.T. BOX CI DES. 2(B)	INLET W/ SMALL I.C.T. BOX CI DES. 2(D)	INLET CI DES. 3(B)	STORM SEWER PIPE	
										15"	18"
										ROUND	ROUND
8.1	200+56.54	80.02	RT	CONST. 8'-15" CPP PIPE W/ 4' MH	SPI-5-1; MJB-4-1	1				8	
8.2	200+56.51	38.26	RT	CONST. 42'-15" CPP PIPE W/ 4' MH	SPI-5-1; MJB-4-1	1				42	
8.3	200+80.44	16.33	RT	CONST. 33'-15" CPP PIPE W/ CICI DESIGN 2(B) W/ SJB	SPI-5-1; CI-2-1		1			33	
8.4	200+80.44	13.00	LT	CONST. 30'-15" CPP PIPE W/ CICI DESIGN 3(B)	SPI-5-1; CI-2-1				1	30	
9.1	209+98.31	41.52	RT	CONST. 95'-18" CPP PIPE W/ 4' MH	SPI-5-1; MJB-4-1	1				95	
9.2	209+80.47	16.33	RT	CONST. 31'-18" CPP PIPE W/ CICI DESIGN 2(D) W/ SJB	SPI-5-1; CI-2-1			1		31	
9.3	206+93.86	16.33	RT	CONST. 287'-15" CPP PIPE W/ CICI DESIGN 2(D) W/ SJB	SPI-5-1; CI-2-1			1		287	
9.4	206+93.86	13.00	LT	CONST. 30'-15" CPP PIPE W/ CICI DESIGN 3(B)	SPI-5-1; CI-2-1				1	30	
10.1	209+80.55	13.00	LT	CONST. 30'-15" CPP PIPE W/ CICI DESIGN 3(B)	SPI-5-1; CI-2-1				1	30	
TOTALS						3	1	2	3	460	126

DESIGN	DGR	5/22	OKLAHOMA DEPARTMENT OF TRANSPORTATION
DRAWN	TSS	5/22	
CHECKED	DGR	5/22	
APPROVED	XXX	XX/XX	
SQUAD	<b>ILCE</b>		
COUNTY	CREEK	STREET	

DRAINAGE AREA MAP

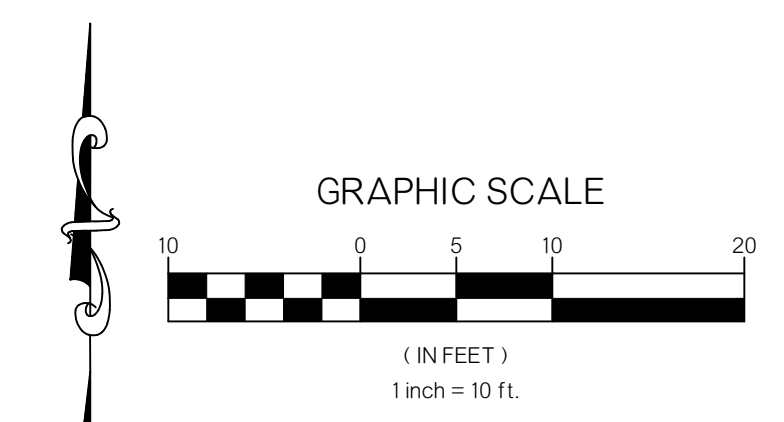
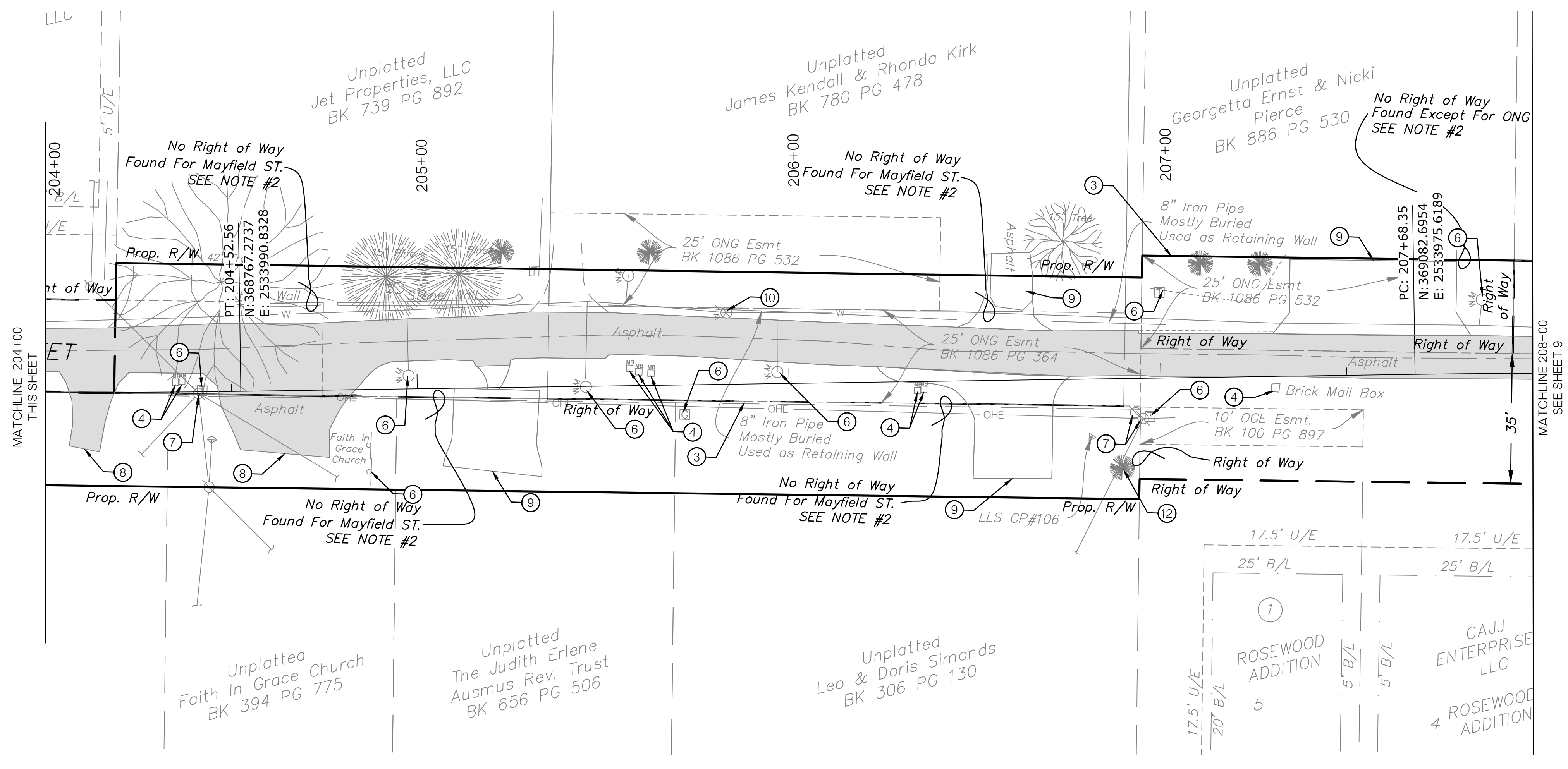
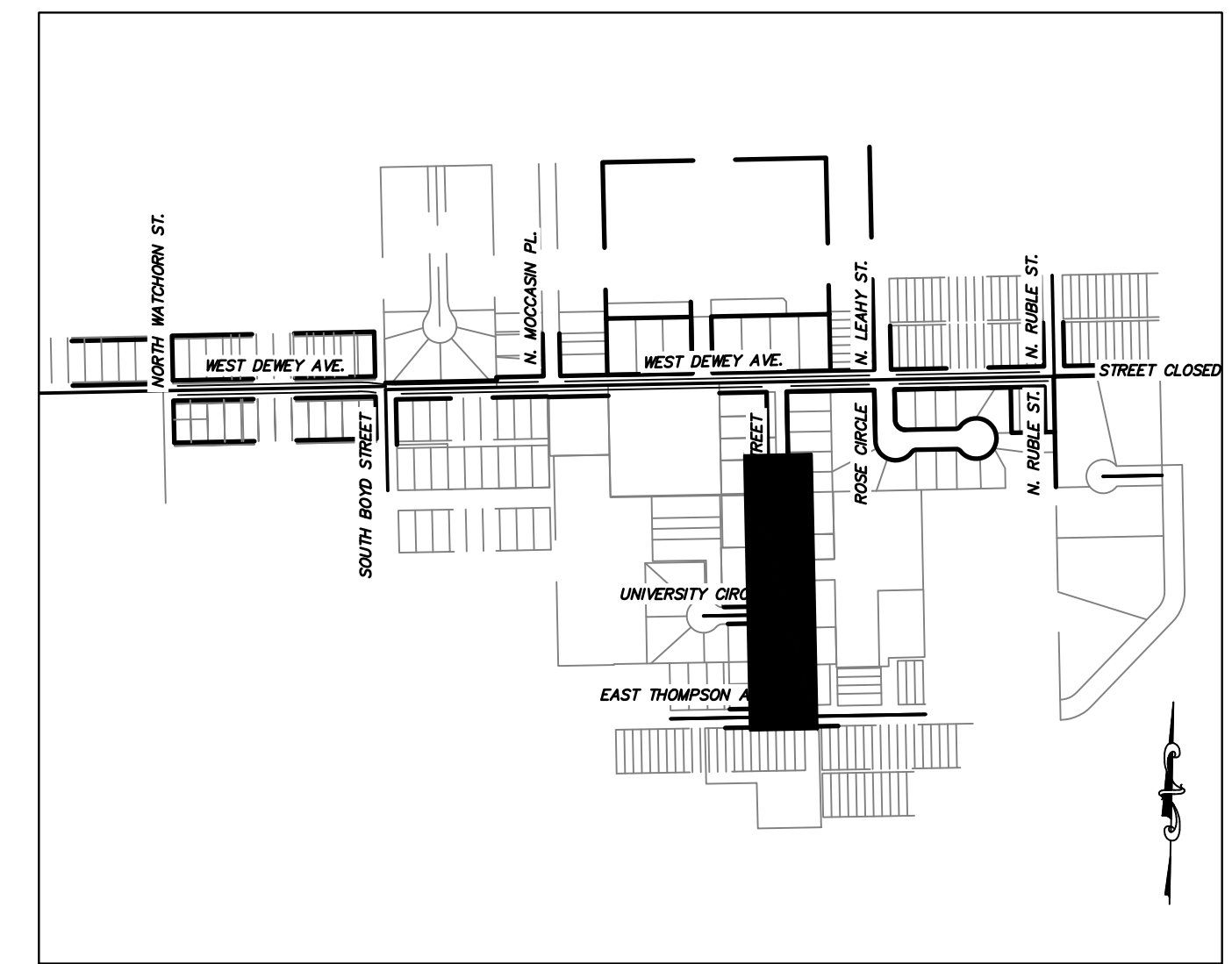
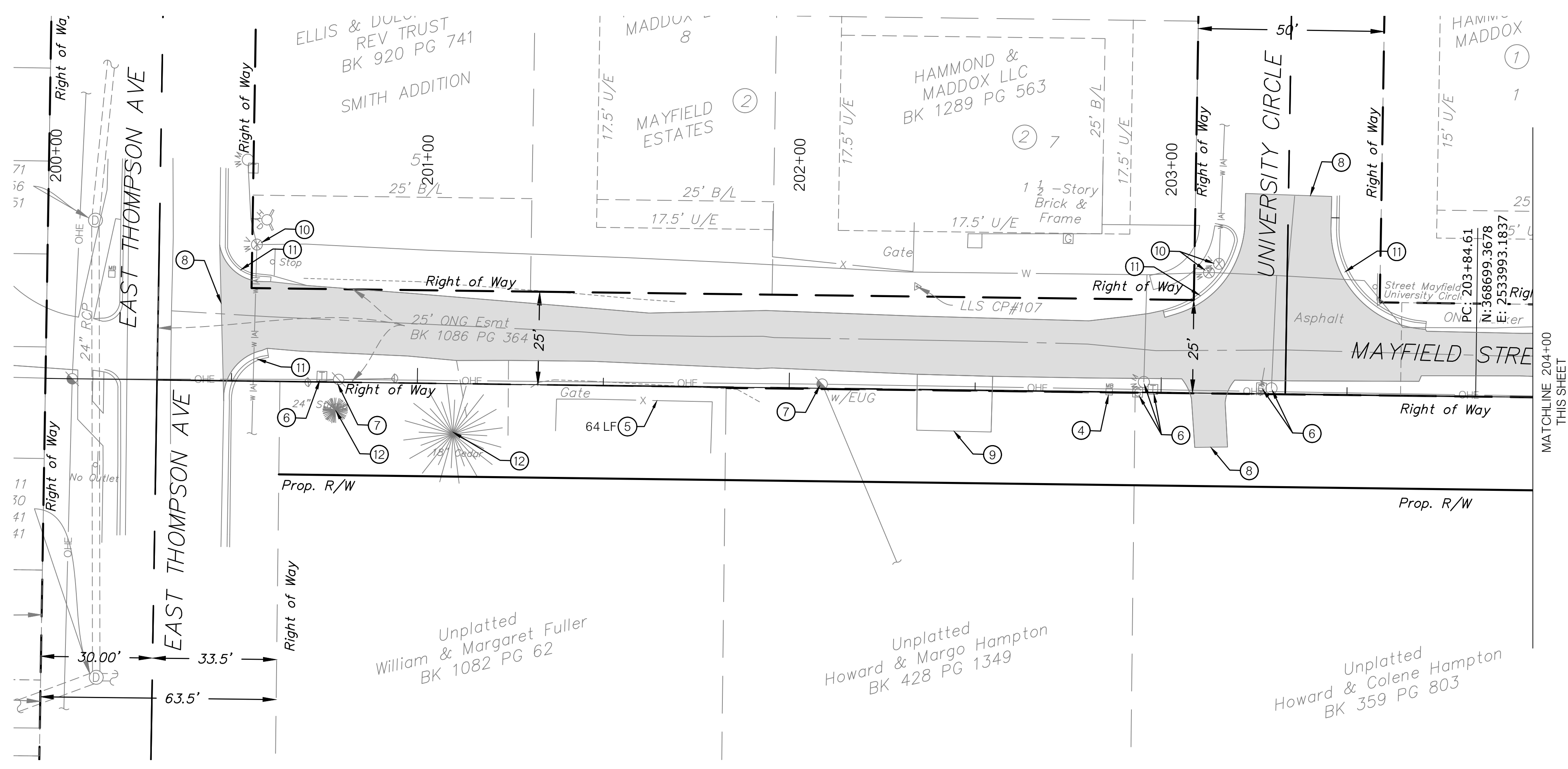

- LEGEND**
- ① DO NOT DISTURB BUSINESS SIGN
  - ② REMOVE EXISTING STRUCTURE
  - ③ REMOVE EXISTING PIPE (LF)
  - ④ REMOVE AND REPLACE MAILBOX
  - ⑤ REMOVE AND REPLACE FENCE (LF)
  - ⑥ TO BE RELOCATED BY OTHERS
  - ⑦ REMOVE AND RELOCATE OR RESET POWER/LIGHT POLE BY OTHERS
  - ⑧ SAWING PAVEMENT
  - ⑨ REMOVE CONCRETE/ASPHALT DRIVEWAY
  - ⑩ ADJUST TO GRADE
  - ⑪ REMOVE CURB & GUTTER
  - ⑫ REMOVE TREE
- REMOVE ASPHALT PAVEMENT

DESIGN	DGR	5/22	OKLAHOMA DEPARTMENT OF TRANSPORTATION <b>MAYFIELD ST DEMOLITION</b> (SHEET 1 OF 2)				
DRAWN	TSS	5/22					
CHECKED	DGR	5/22					
APPROVED	XXX	XX/XX					
SQUAD	<b>MICE</b>						
COUNTY	CREEK	STREET	MAYFIELD ST	STATE JOB NO.	N/A	SHEET NO.	8

PLOT DATE: 5/3/2022 12:14 AM. DRAWING NAME: 217109 DEMOLITION.DWG



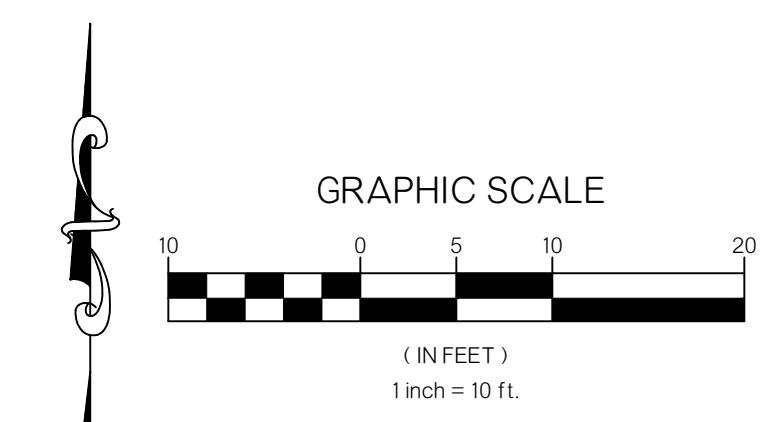
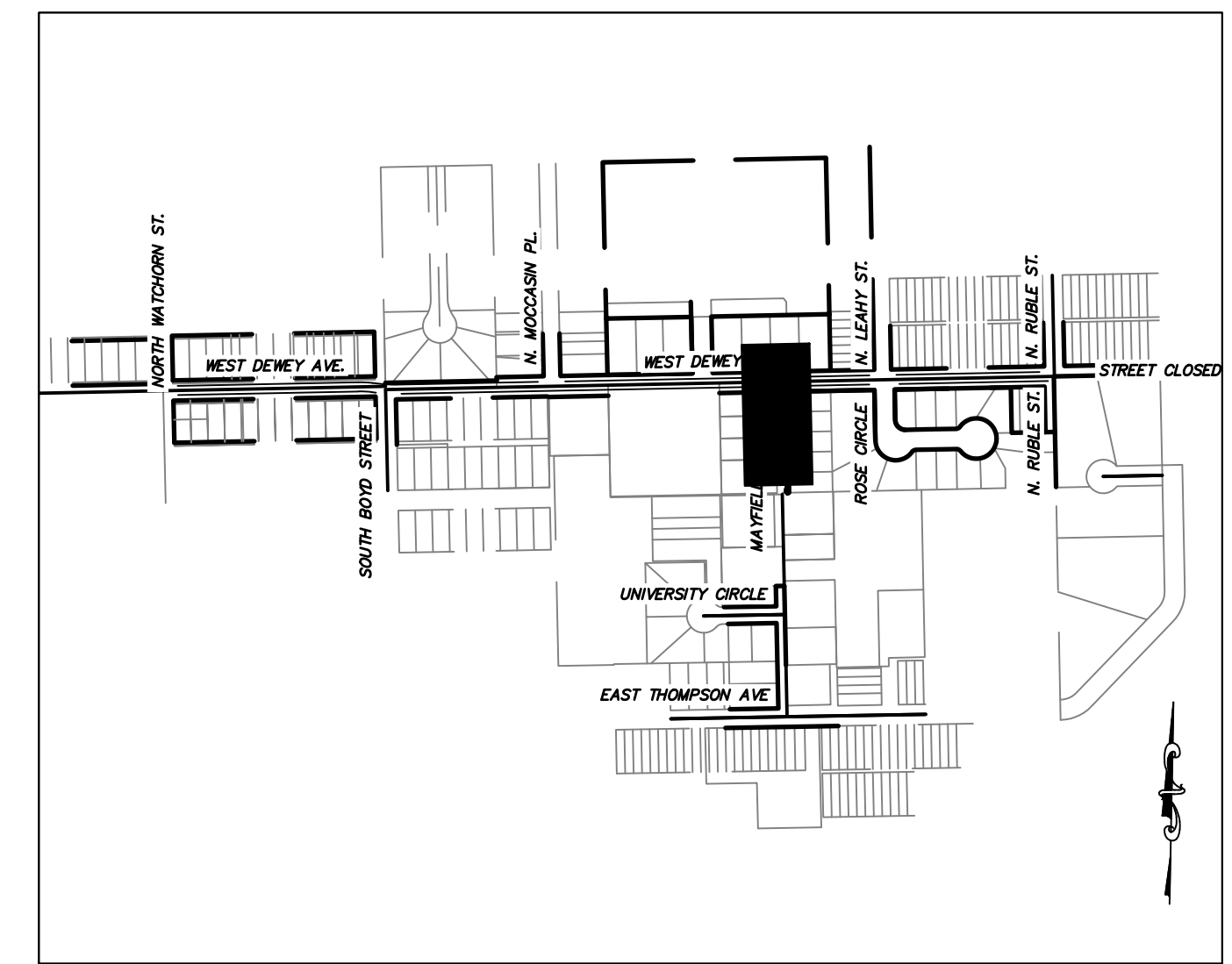
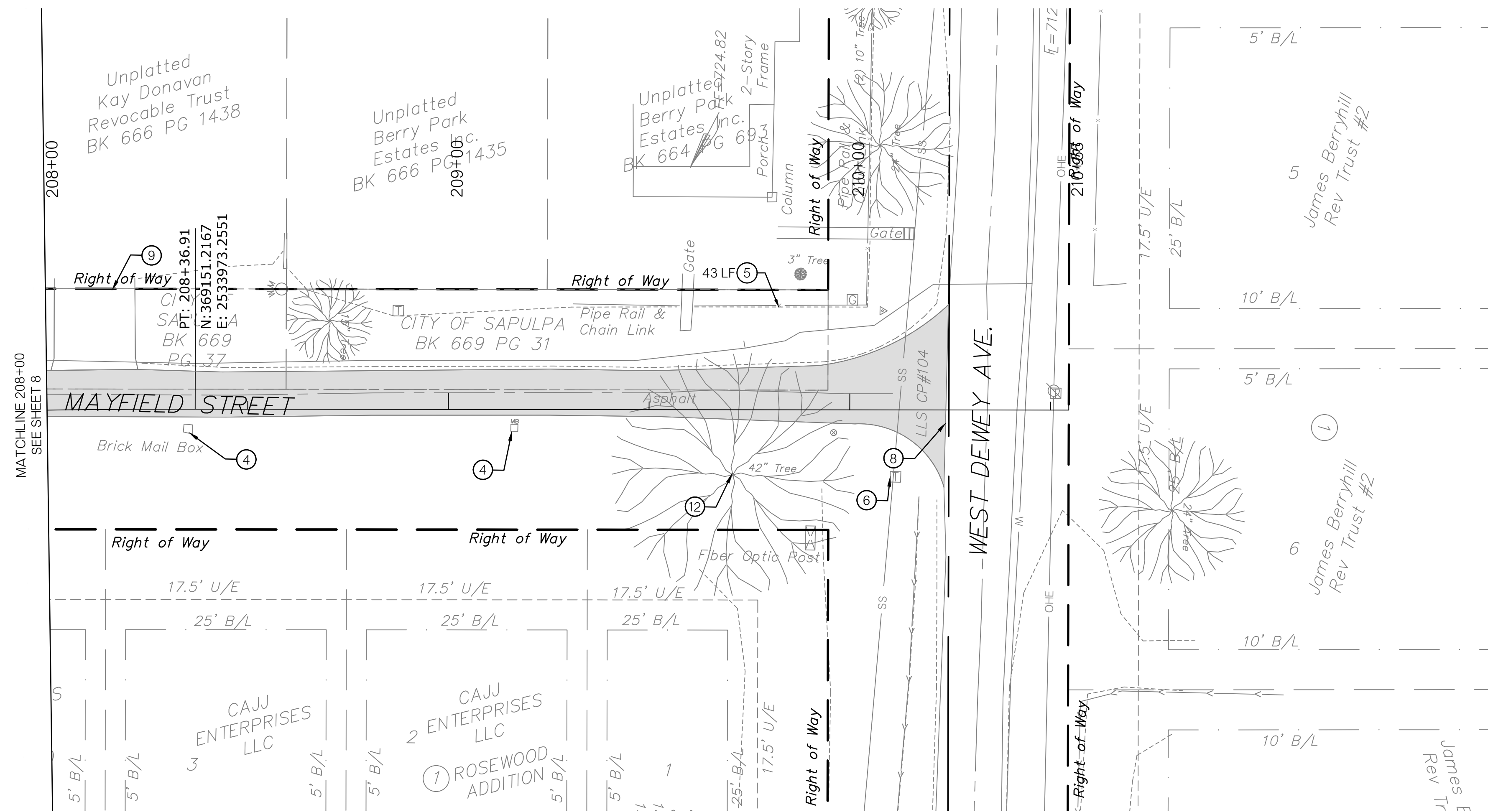







LEGEND

- ① DO NOT DISTURB BUSINESS SIGN
  - ② REMOVE EXISTING STRUCTURE
  - ③ REMOVE EXISTING PIPE (LF)
  - ④ REMOVE AND REPLACE MAILBOX
  - ⑤ REMOVE AND REPLACE FENCE (LF)
  - ⑥ TO BE RELOCATED BY OTHERS
  - ⑦ REMOVE AND RELOCATE OR RESET POWER/LIGHT POLE BY OTHERS
  - ⑧ SAWING PAVEMENT
  - ⑨ REMOVE CONCRETE/ASPHALT DRIVEWAY
  - ⑩ ADJUST TO GRADE
  - ⑪ REMOVE CURB & GUTTER
  - ⑫ REMOVE TREE
- REMOVE ASPHALT PAVEMENT

PLOT DATE: 5/3/2022 12:14 AM, DRAWING NAME: 217109 DEMOLITION.DWG

DESIGN	DGR	5/22	OKLAHOMA DEPARTMENT OF TRANSPORTATION <b>MAYFIELD ST DEMOLITION</b> (SHEET 2 OF 2)				
DRAWN	TSS	5/22					
CHECKED	DGR	5/22					
APPROVED	XXX	XX/XX					
SQUAD	<b>MCE</b>						
COUNTY	CREEK	STREET	MAYFIELD ST	STATE JOB NO.	N/A	SHEET NO.	9

LEGEND:

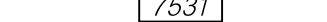
-  RIGHT OF WAY
-  RIGHT OF WAY BEFORE ACQUISITION
-  PROPERTY LINE
-  CENTERLINE OF ROAD
-  RIGHT OF WAY ACQUISITION AREA
-  TEMPORARY CONSTRUCTION EASEMENT
-  PROPERTY ADDRESS
-  BENCHMARK

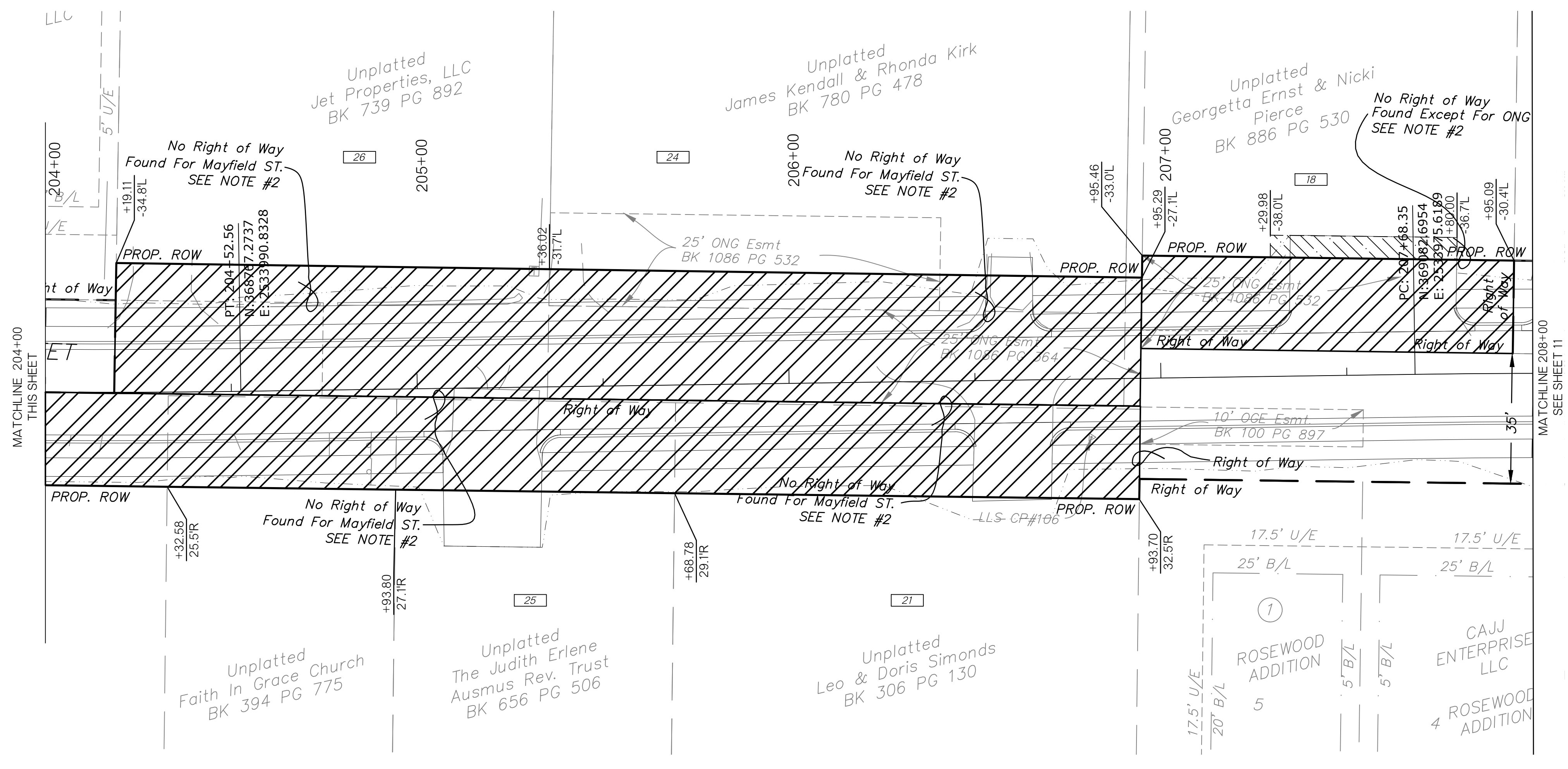
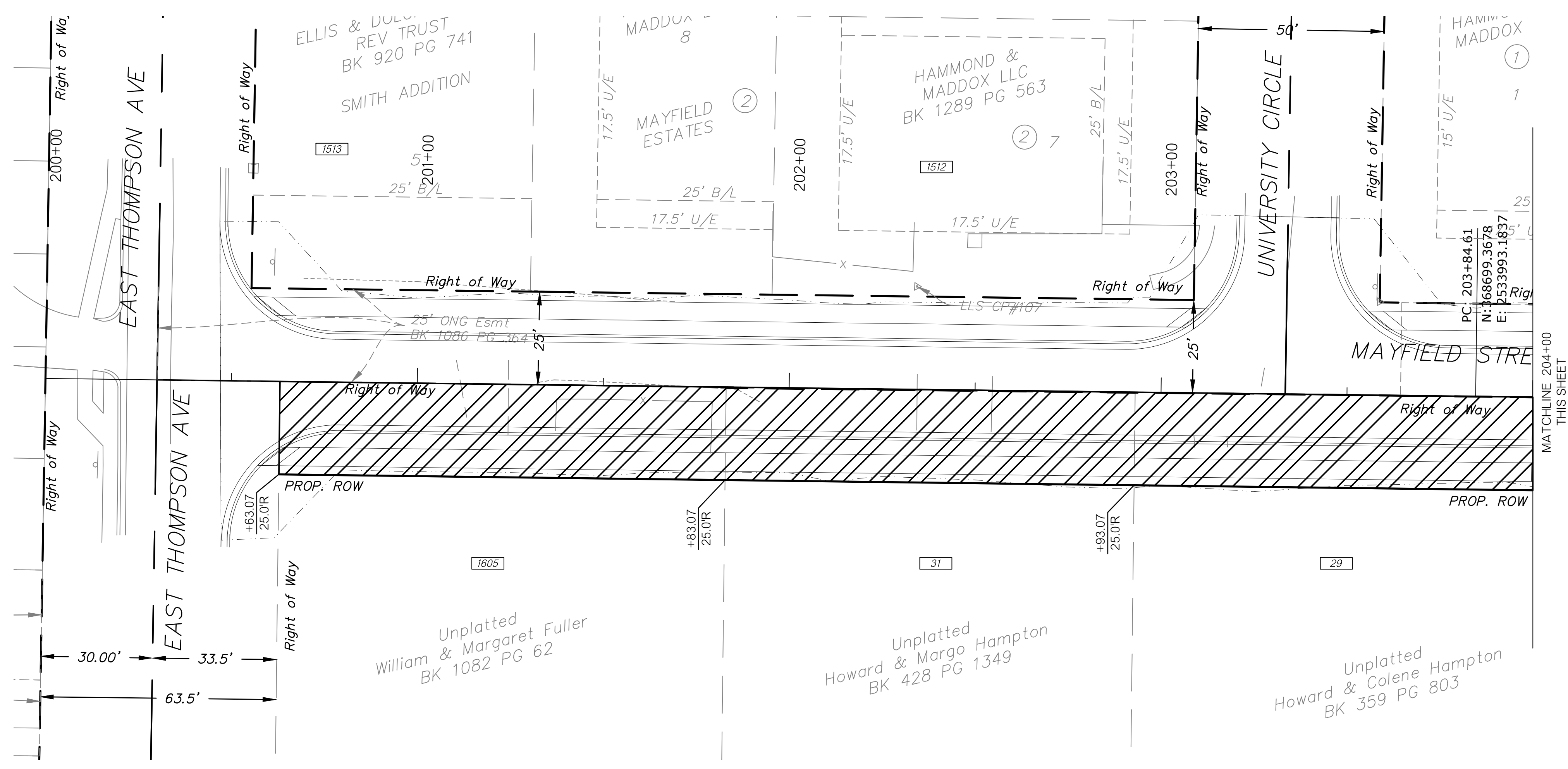
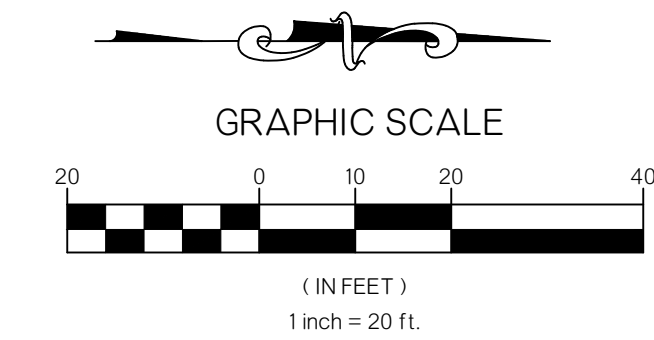

ROW & TEMPORARY CONSTRUCTION EASEMENT TABLE						
NO	DOC. # / BOOK & PAGE #	OWNER	START STA.	END STA.	PERMANENT ROW	TEMPORARY CONSTRUCTION EASEMENT
1605	BK 1082 PG 62	William & Margaret Fuller	200+63.07, 25.0' RT	201+83.07, 25.0' RT	X	
31	BK 428 PG 1349	Howard & Margo Hampton	201+83.07, 25.0' RT	202+93.07, 25.0' RT	X	
29	BK 359 PG 803	Howard & Colene Hampton	202+93.07, 25.0' RT	204+32.58, 25.5' RT	X	
26	BK 739 PG 892	Jet Properties, LLC	204+19.11, 34.8' LT	205+36.02, 31.7' LT	X	
25	BK 656 PG 506	Judith Erlene Ausmus Rev. Trust	204+32.58, 25.5' LT	204+93.80, 27.1' LT	X	
24	BK 780 PG 478	James Kendall & Rhonda Kirk	205+36.05, 31.7' LT	206+95.29, 27.1' LT	X	
21	BK 306 PG 130	Leo & Doris Simonds	205+68.78, 29.1' RT	206+93.70, 32.5' RT	X	
18	BK 886 PG 530	Georgetta Ernst & Nicki Pierce	206+95.46, 33.0' LT	207+95.09, 30.4' LT	X	
18	BK 886 PG 530	Georgetta Ernst & Nicki Pierce	207+29.98, 38.0' LT	207+80.00, 36.7' LT		X

DESIGN	DGR	5/22	OKLAHOMA DEPARTMENT OF TRANSPORTATION	
DRAWN	TSS	5/22		
CHECKED	DGR	5/22		
APPROVED	XXX	XX/XX		
SQUAD				
COUNTY	CREEK	STREET		MAYFIELD ST.
			STATE JOB NO.	N/A
			SHEET NO.	10

RIGHT OF WAY  
(SHEET 1 OF 2)

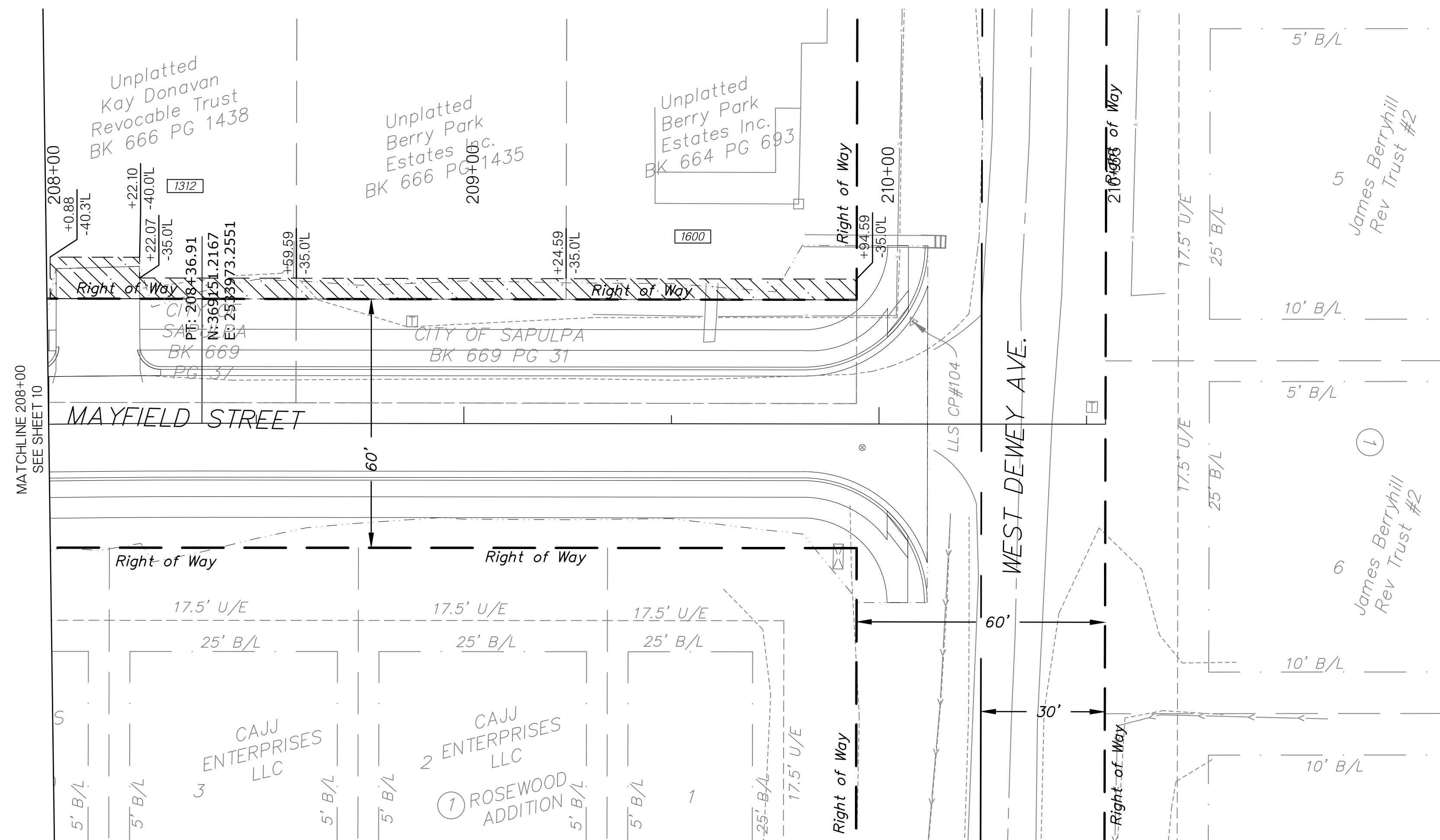

LEGEND:

- RIGHT OF WAY
- RIGHT OF WAY BEFORE ACQUISITION
- PROPERTY LINE
- CENTERLINE OF ROAD
- RIGHT OF WAY ACQUISITION AREA
- TEMPORARY CONSTRUCTION EASEMENT
- PROPERTY ADDRESS BENCHMARK

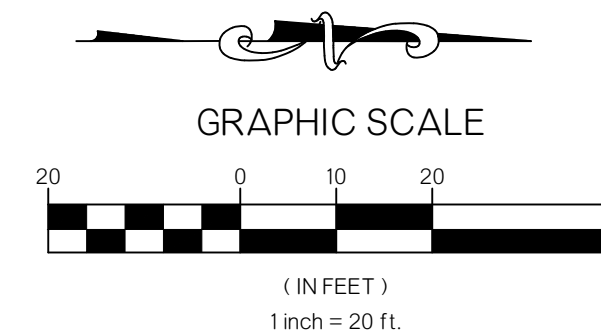

ROW & TEMPORARY CONSTRUCTION EASEMENT TABLE						
NO	DOC. # / BOOK & PAGE #	OWNER	START STA.	END STA.	PERMANENT ROW	TEMPORARY CONSTRUCTION EASEMENT
1312	BK 666 PG 1438	KAY DONAVAN REVOCABLE TRUST	208+00.88, 40.3' LT	208+22.10, 40.0' LT		X
1312	BK 666 PG 1438	KAY DONAVAN REVOCABLE TRUST	208+22.07, 35.0' LT	208+59.59, 35.0' LT		X
N/A	BK 666 PG 1435	BERRY PARK ESTATES INC.	208+59.59, 35.0' LT	209+24.59, 35.0' LT		X
N/A	BK 664 PG 693	BERRY PARK ESTATES INC.	209+24.59, 35.0' LT	209+94.59, 35.0' LT		X

DESIGN	DGR	5/22	OKLAHOMA DEPARTMENT OF TRANSPORTATION
DRAWN	TSS	5/22	
CHECKED	DGR	5/22	
APPROVED	XXX	XX/XX	
SQUAD			
COUNTY	CREEK	STREET	

RIGHT OF WAY  
(SHEET 2 OF 2)

COUNTY CREEK STREET MAYFIELD ST STATE JOB NO. N/A SHEET NO. 11

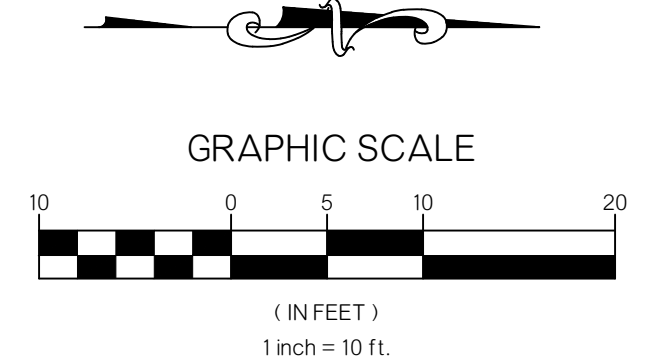
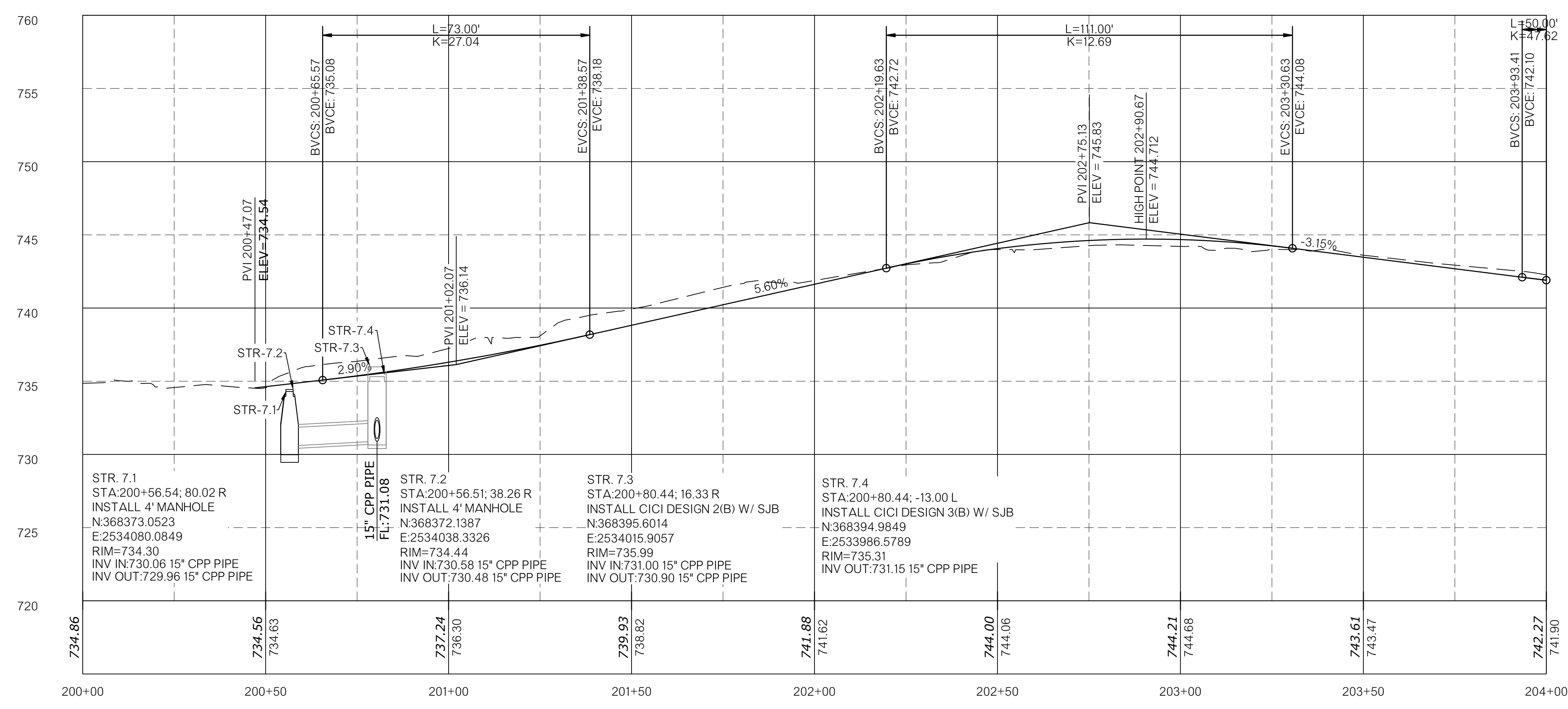
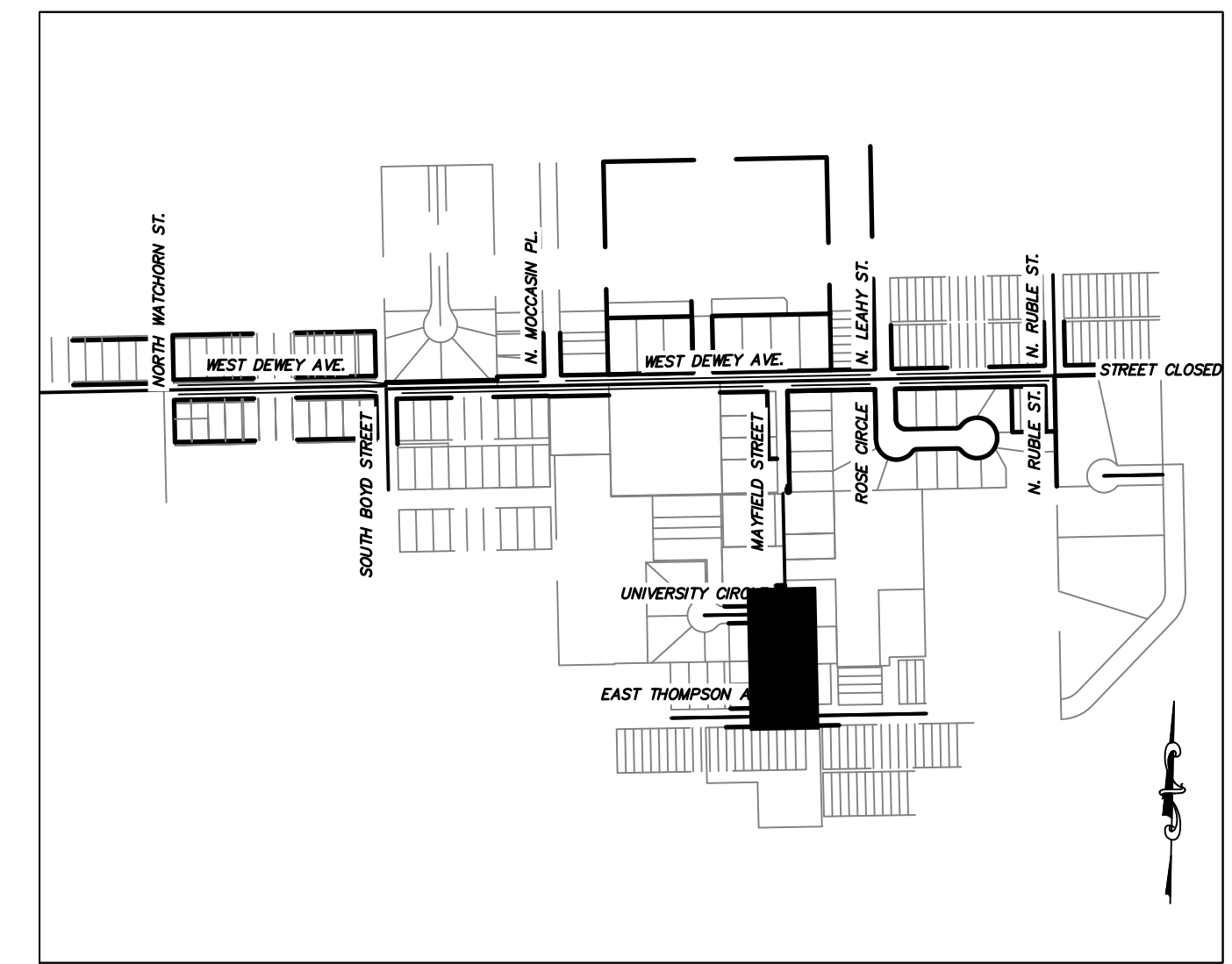
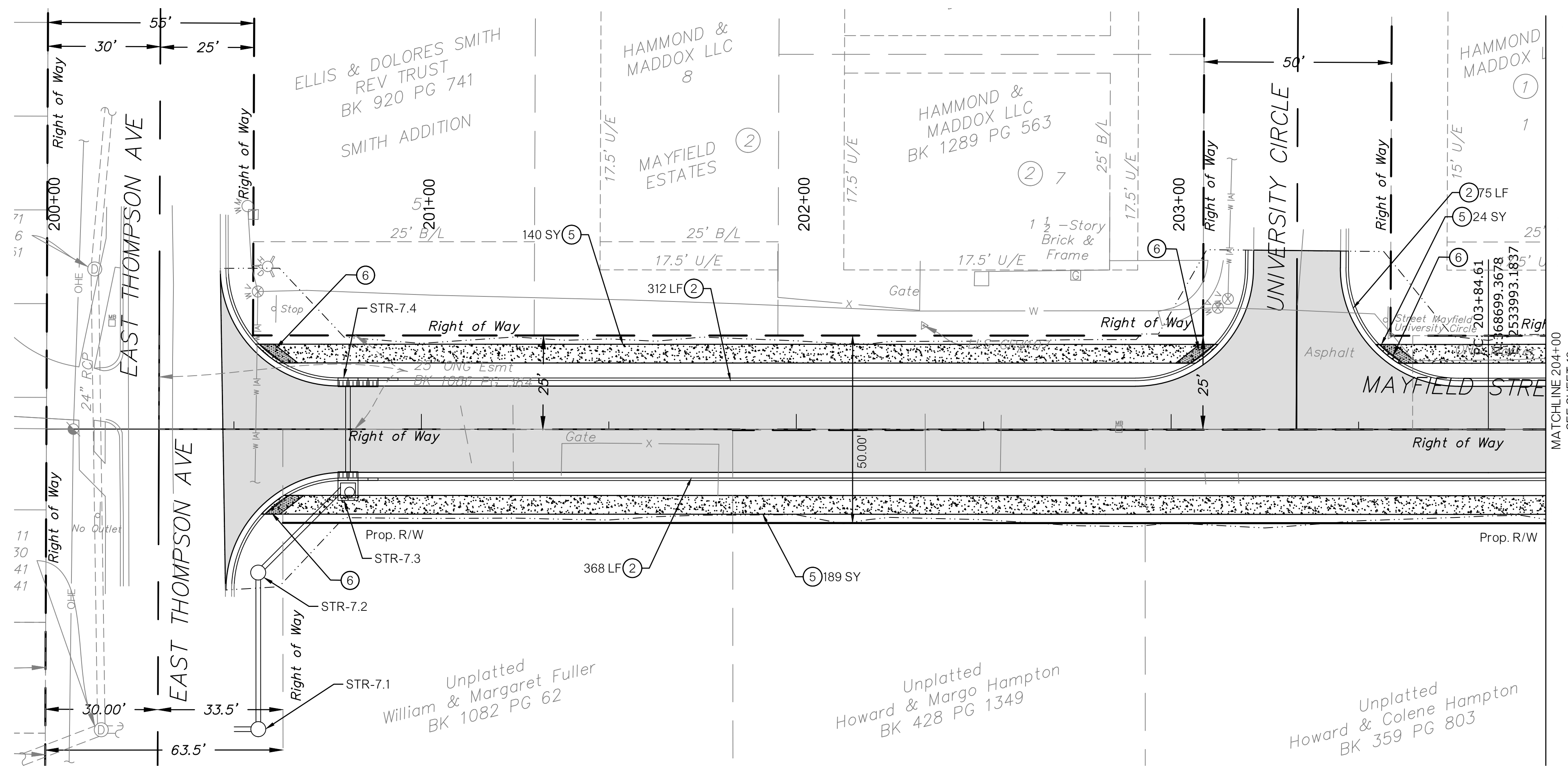

LEGEND

- ① DRIVEWAY (PCC)
- ② CURB AND GUTTER
- ③ ADJUST TO GRADE
- ④ PROTECT TREE
- ⑤ CONCRETE SIDEWALK
- ⑥ HANDICAP RAMP WITH TACTILE WARNING PANEL
- TBM 1012 BENCHMARK
- DRAINAGE DIRECTION
- CONCRETE SIDEWALK
- CONCRETE DRIVEWAY
- FULL DEPTH PAVEMENT
- EXISTING GRADE
- FINISHED GRADE
- TOC/TOS

DESIGN	DGR	5/22	OKLAHOMA DEPARTMENT OF TRANSPORTATION <b>MAYFIELD ST PLAN &amp; PROFILE</b> (SHEET 1 OF 3)				
DRAWN	TSS	5/22					
CHECKED	DGR	5/22					
APPROVED	XXX	XX/XX					
SQUAD	<b>ILCE</b>						
COUNTY	CREEK	STREET	MAYFIELD ST	STATE JOB NO.	N/A	SHEET NO.	12

PLOT DATE: 5/3/2022 12:15 AM. DRAWING NAME: 217109 PLAN & PROFILE.DWG

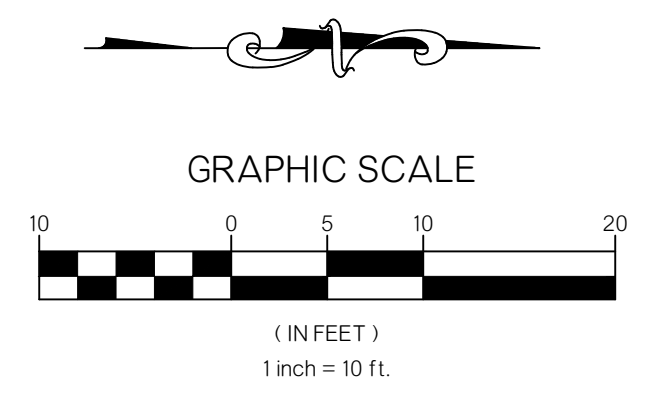
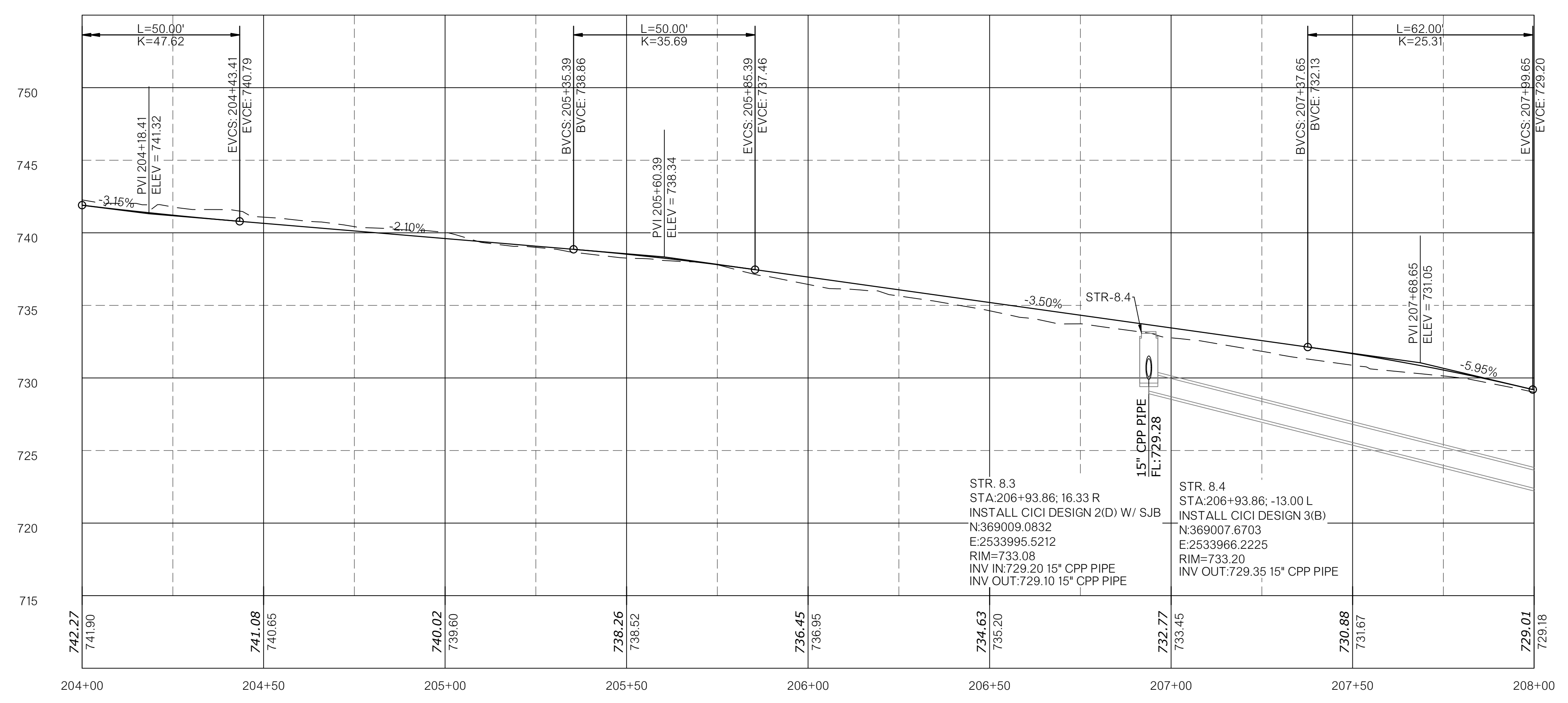
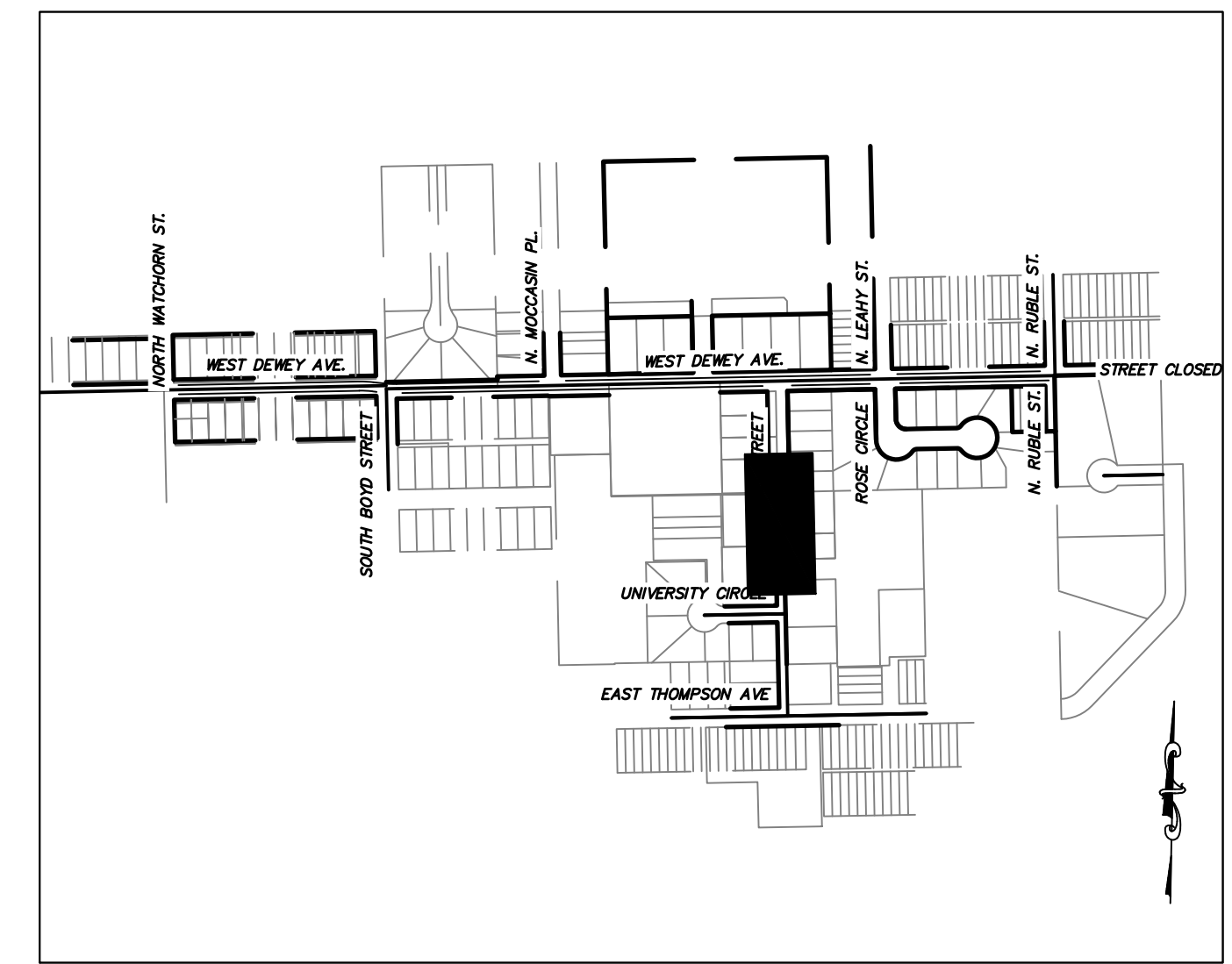
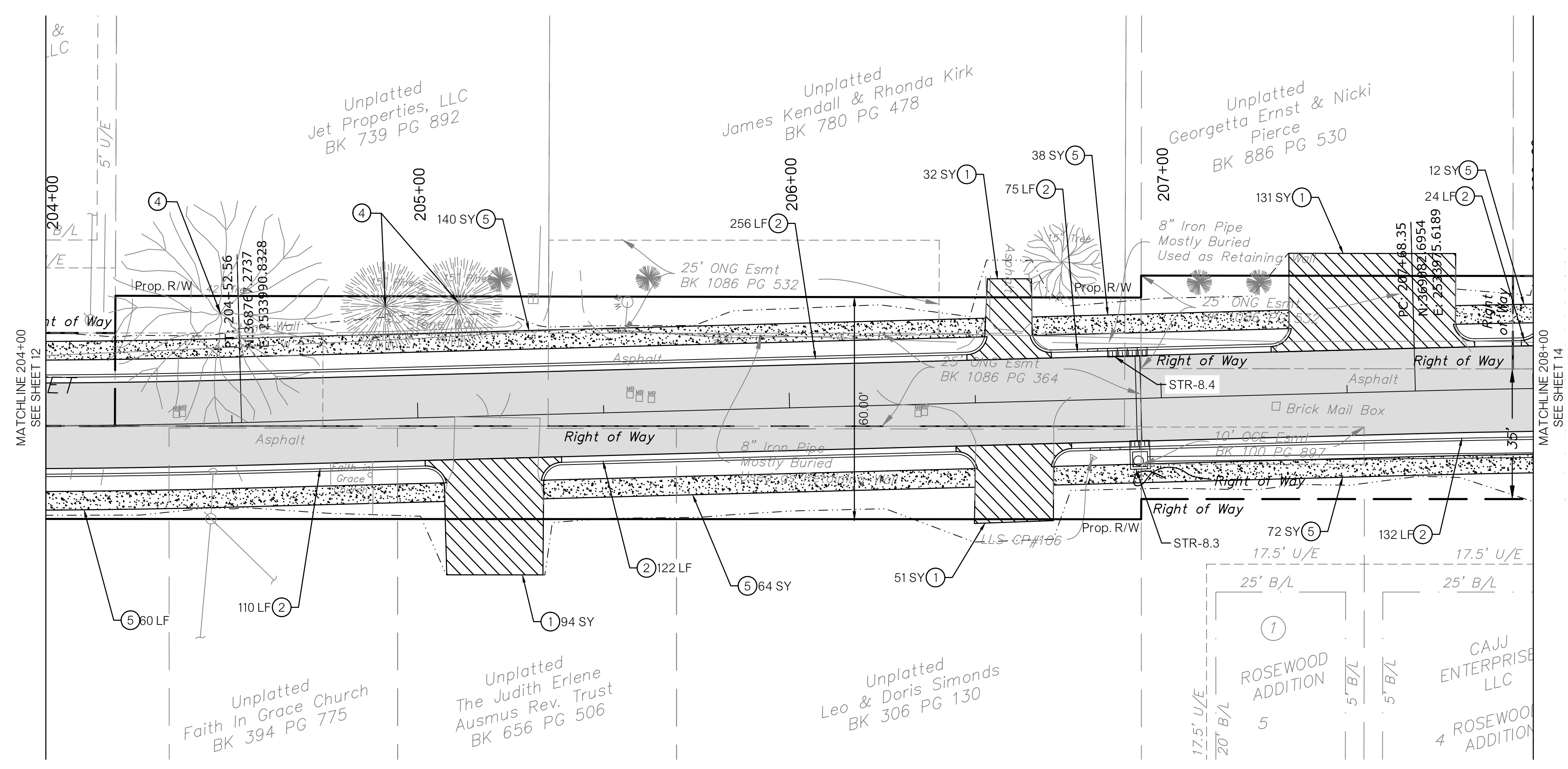

**LEGEND**

① DRIVEWAY (PCC)	TBM 1012 BENCHMARK
② CURB AND GUTTER	DRAINAGE DIRECTION
③ ADJUST TO GRADE	CONCRETE SIDEWALK
④ PROTECT TREE	CONCRETE DRIVEWAY
⑤ CONCRETE SIDEWALK	FULL DEPTH PAVEMENT
⑥ HANDICAP RAMP WITH TACTILE WARNING PANEL	EXISTING GRADE FINISHED GRADE
	TOC/TOS

DESIGN	DGR	5/22	OKLAHOMA DEPARTMENT OF TRANSPORTATION
DRAWN	TSS	5/22	
CHECKED	DGR	5/22	
APPROVED	XXX	XX/XX	
SQUAD			
COUNTY CREEK STREET MAYFIELD ST STATE JOB NO. N/A SHEET NO. 13			

PLOT DATE: 5/3/2022 12:15 AM. DRAWING NAME: 217109 PLAN & PROFILE.DWG

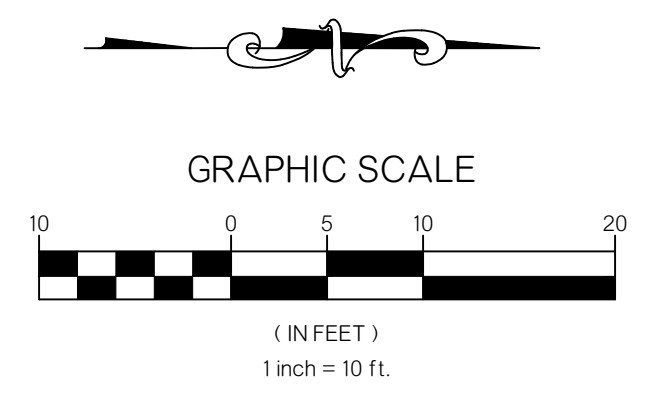
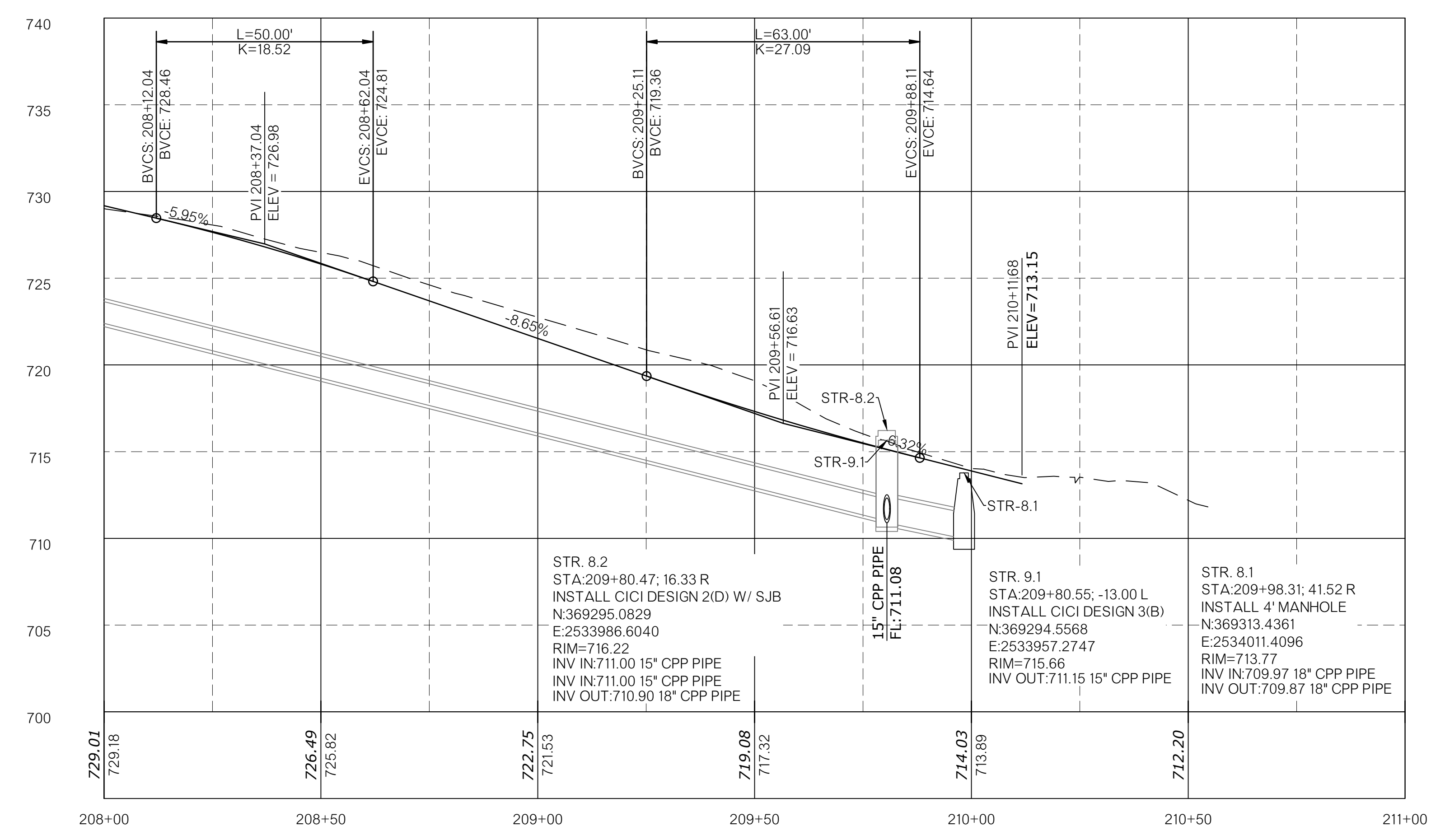
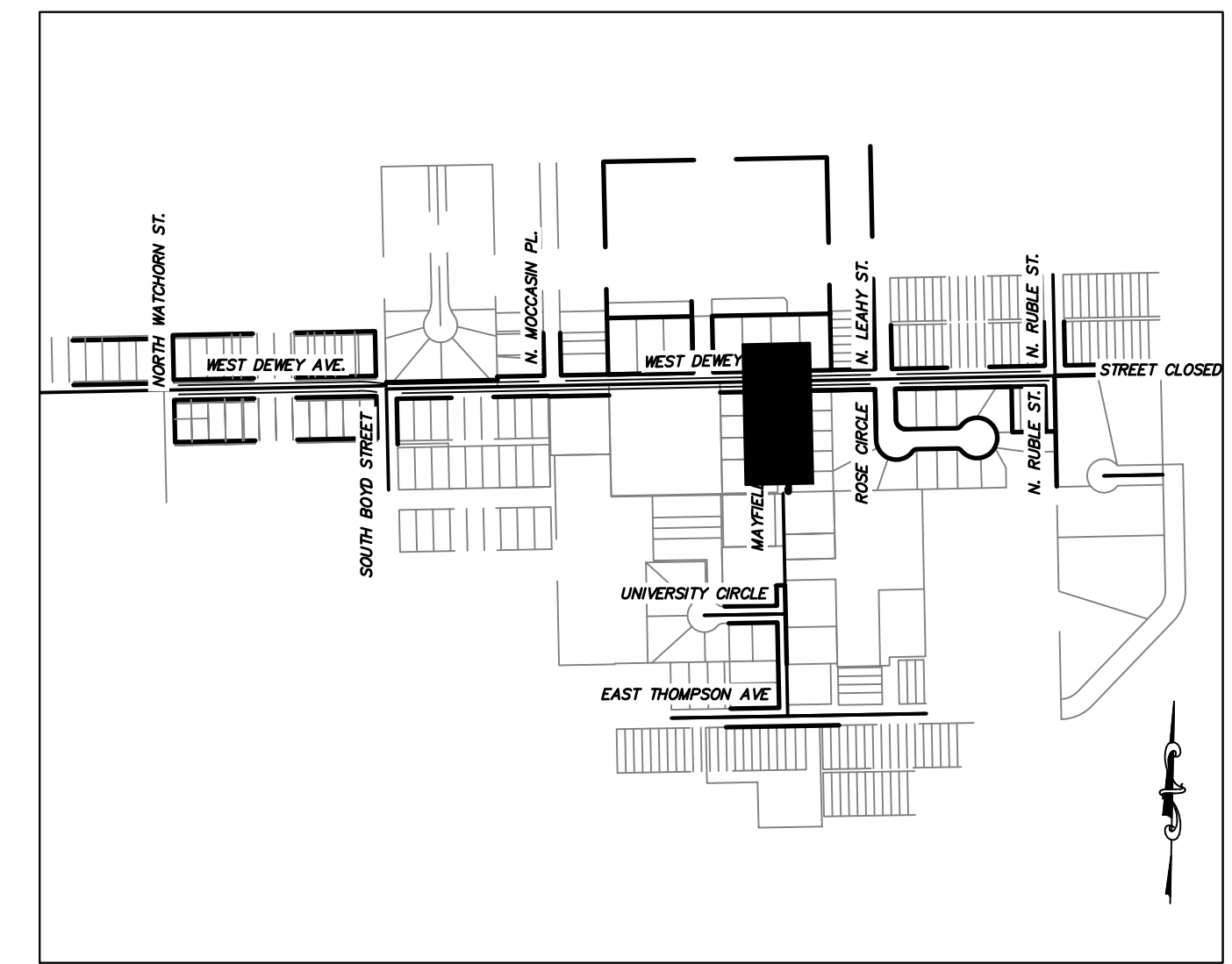
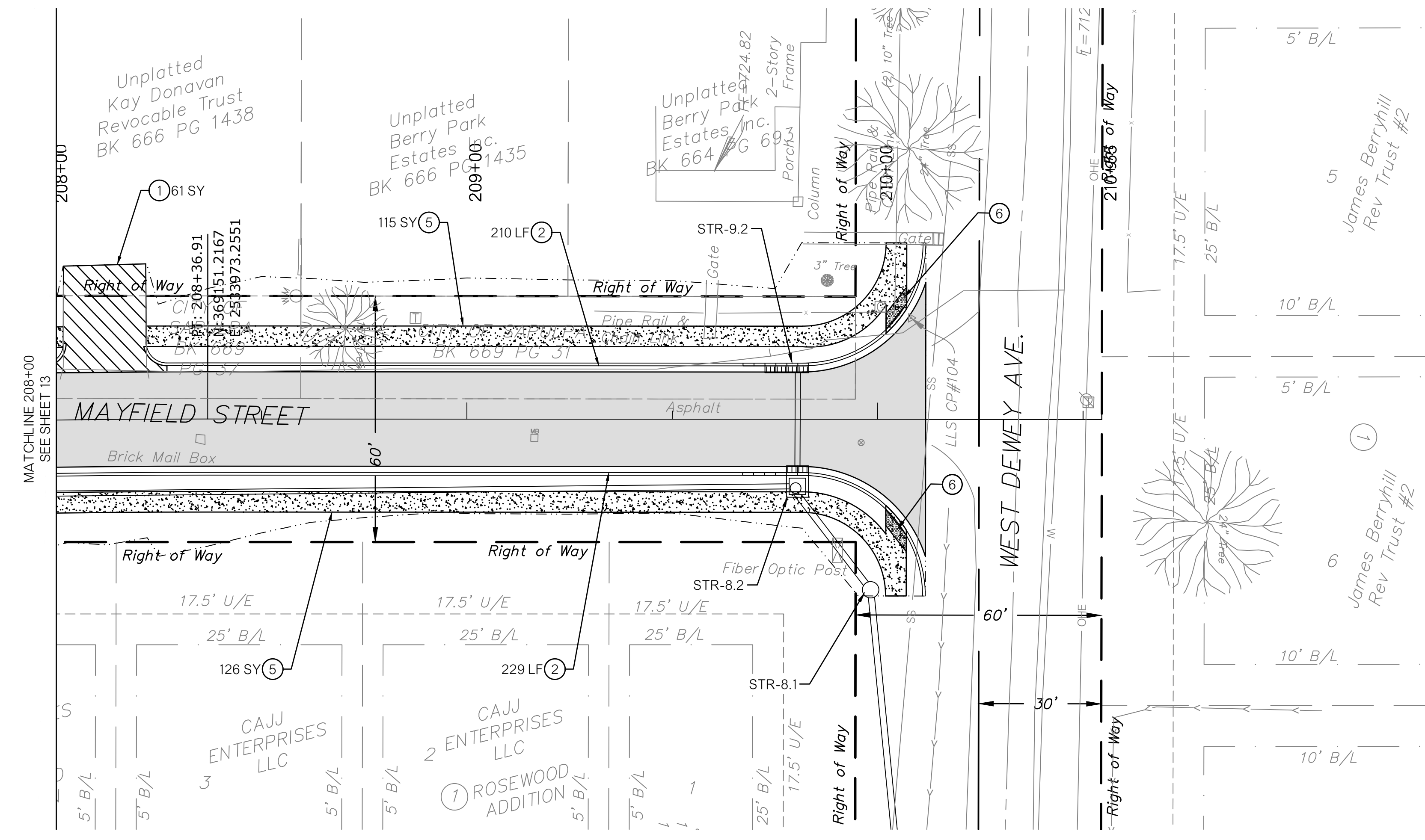

LEGEND

- ① DRIVEWAY (PCC)
- ② CURB AND GUTTER
- ③ ADJUST TO GRADE
- ④ PROTECT TREE
- ⑤ CONCRETE SIDEWALK
- ⑥ HANDICAP RAMP WITH TACTILE WARNING PANEL
- TBM 1012 BENCHMARK
- DRAINAGE DIRECTION
- CONCRETE SIDEWALK
- CONCRETE DRIVEWAY
- FULL DEPTH PAVEMENT
- EXISTING GRADE
- FINISHED GRADE
- TOC/TOS

DESIGN	DGR	5/22	OKLAHOMA DEPARTMENT OF TRANSPORTATION
DRAWN	TSS	5/22	
CHECKED	DGR	5/22	
APPROVED	XXX	XX/XX	
SQUAD	<b>ILCE</b>		
COUNTY <u>CREEK</u> STREET <u>MAYFIELD ST</u> STATE JOB NO. <u>N/A</u> SHEET NO. <u>14</u>			MAYFIELD ST PLAN & PROFILE (SHEET 3 OF 3)

PLOT DATE: 5/3/2022 12:15 AM. DRAWING NAME: 217109 PLAN & PROFILE.DWG

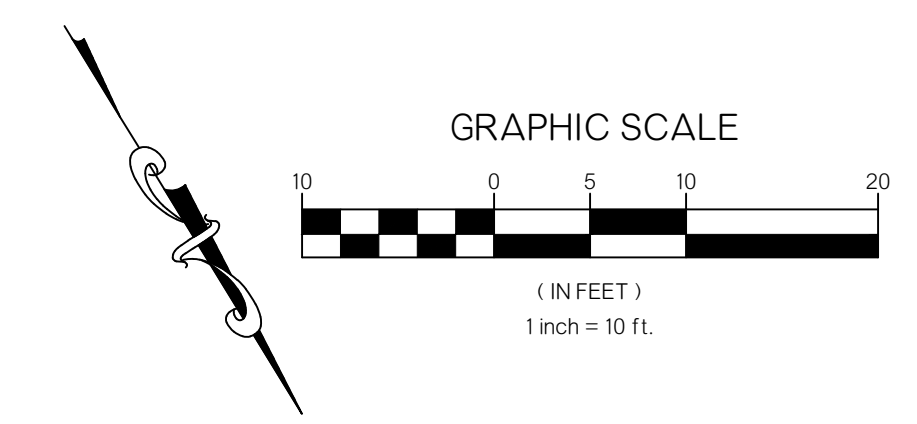
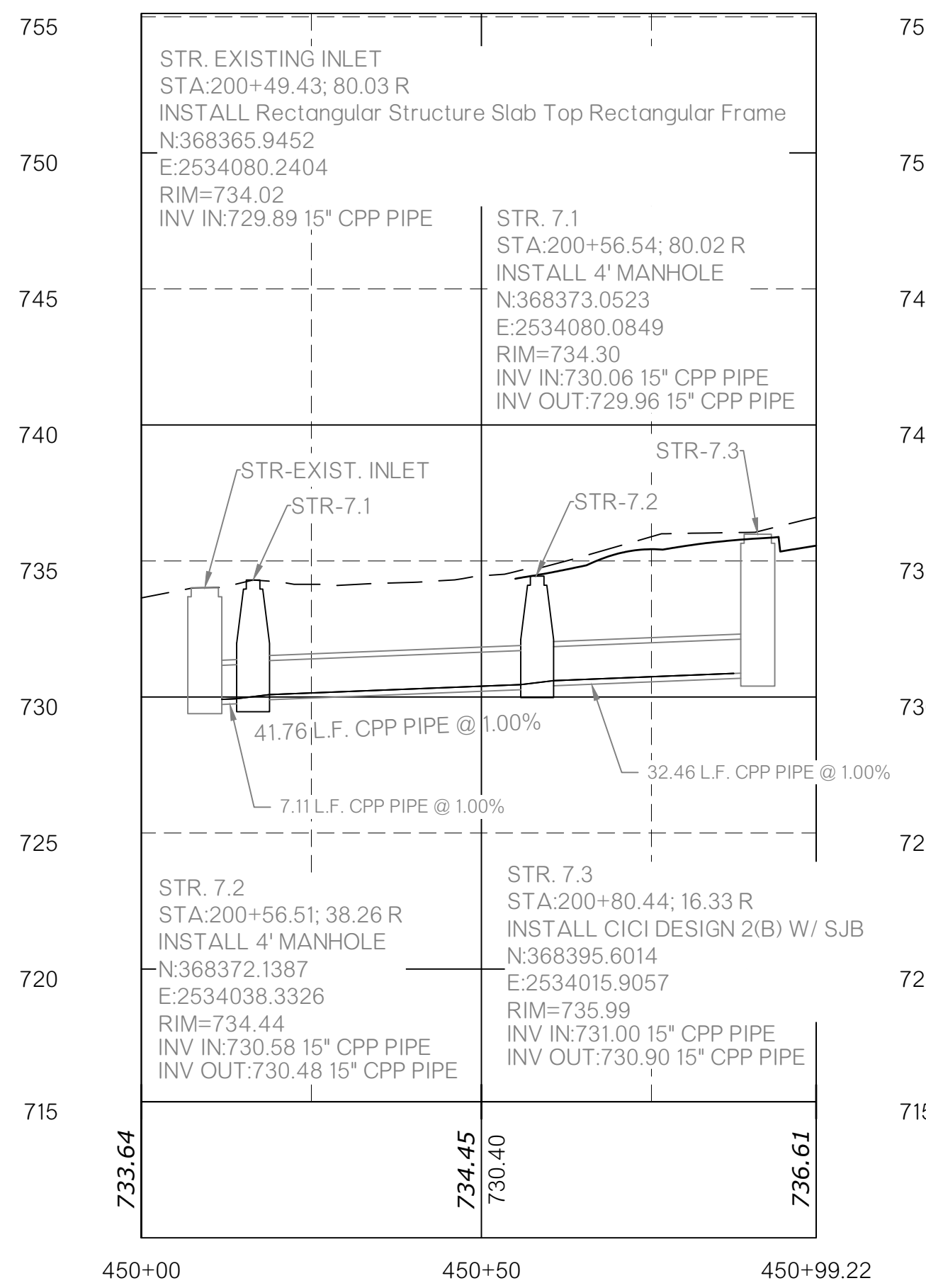
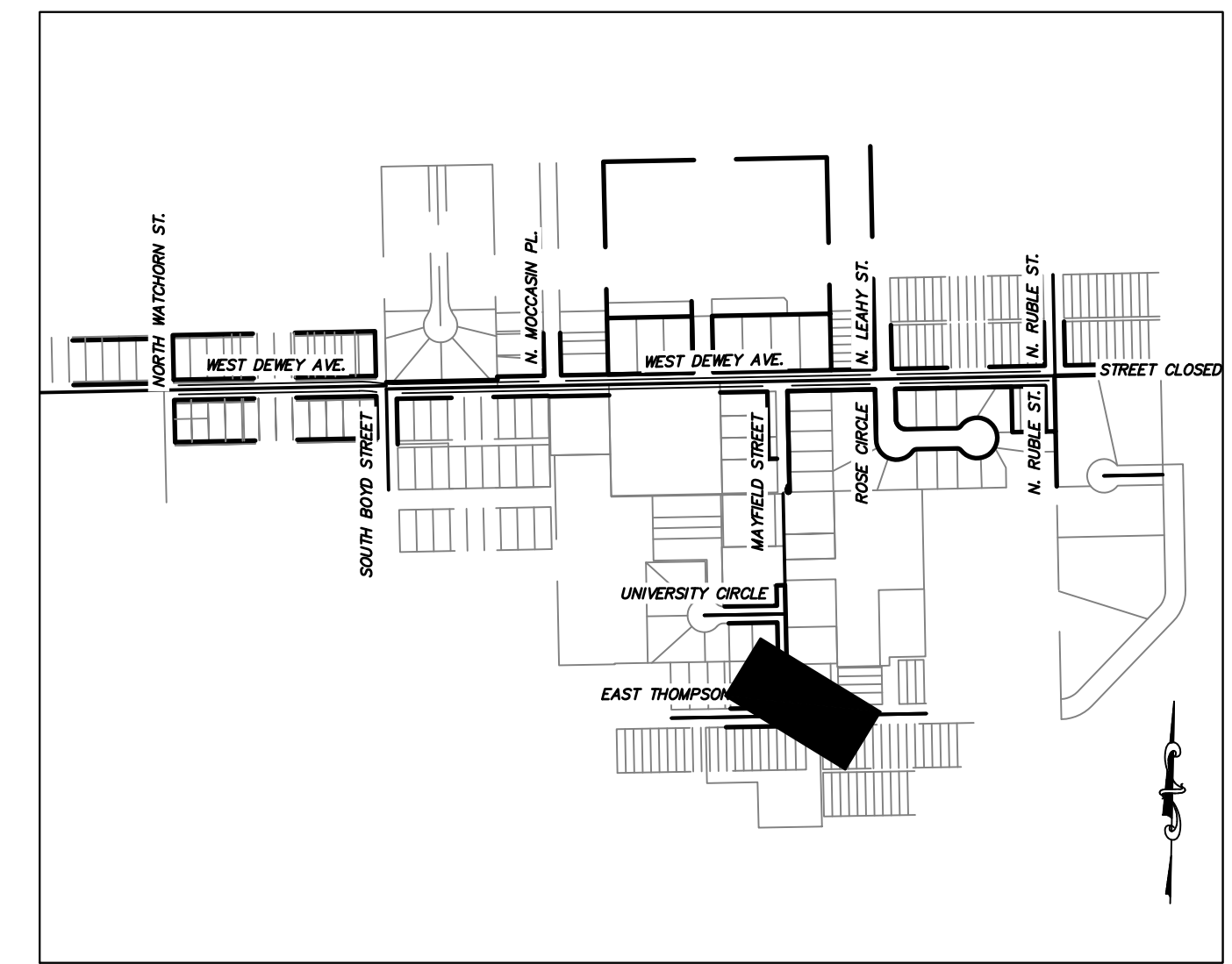
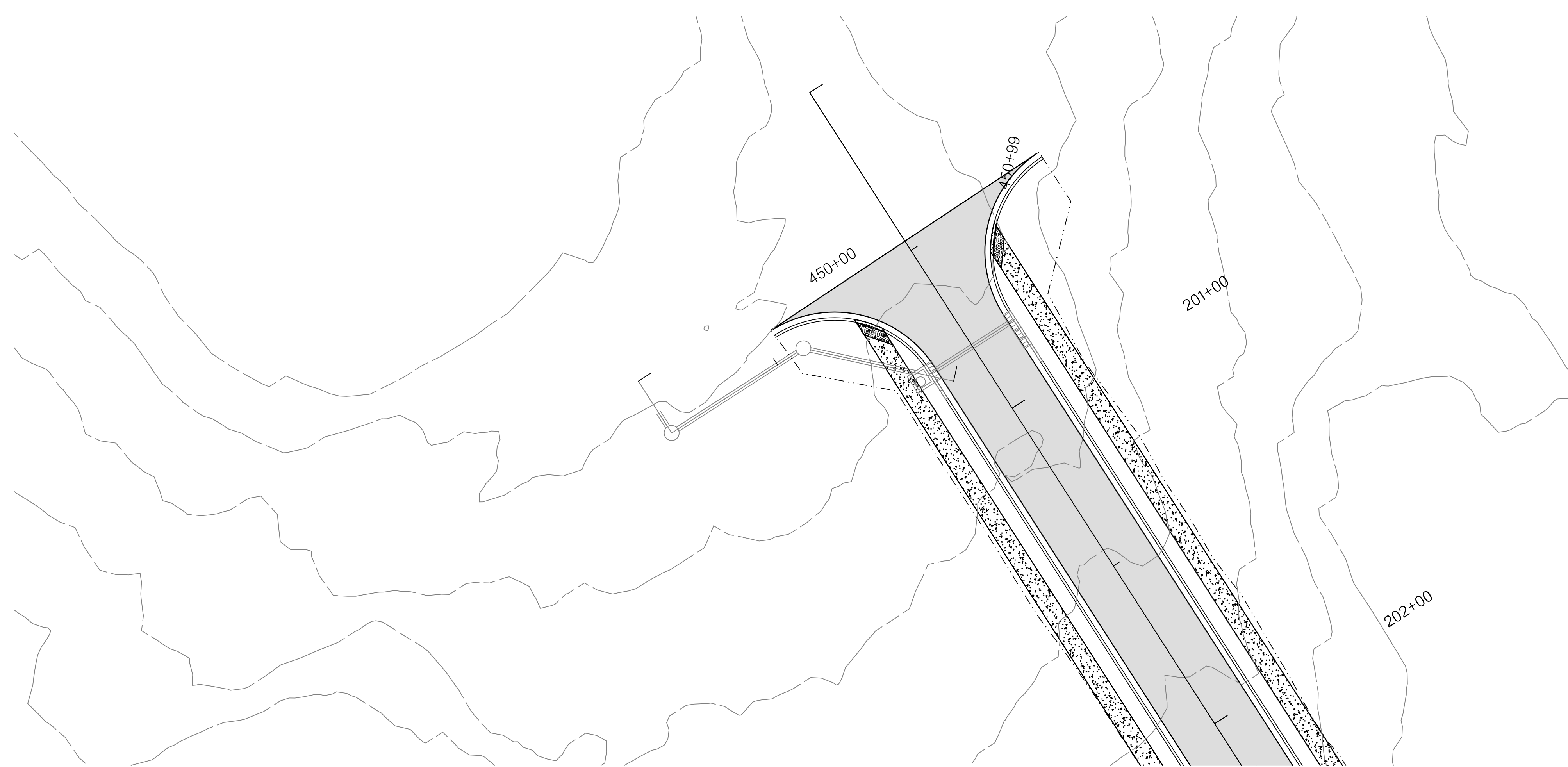

DESIGN	DGR	5/22	OKLAHOMA DEPARTMENT OF TRANSPORTATION
DRAWN	TSS	5/22	
CHECKED	DGR	5/22	
APPROVED	XXX	XX/XX	
SQUAD	<b>MCE</b>		
COUNTY	CREEK	STREET	

7.1 - 7.3 STORM PIPE  
PLAN & PROFILE

STATE JOB NO. N/A SHEET NO. 15

PLOT DATE: 5/3/2022 12:16 AM. DRAWING NAME: 217109 STORM PLAN & PROFILE.DWG

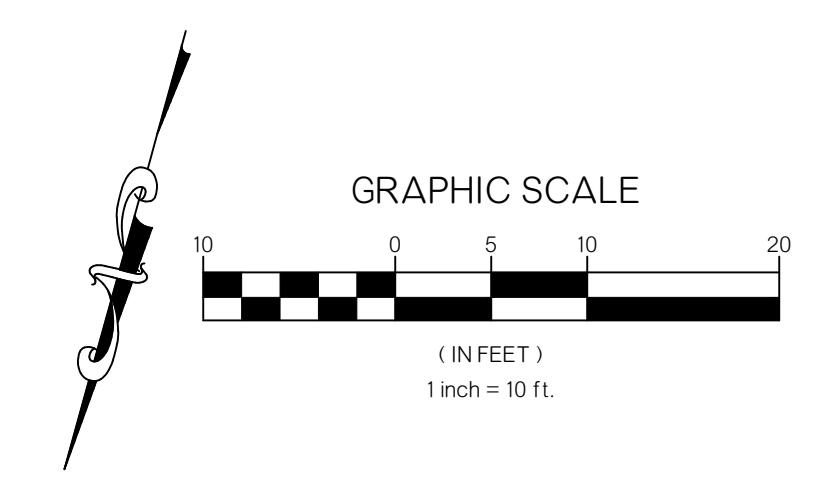
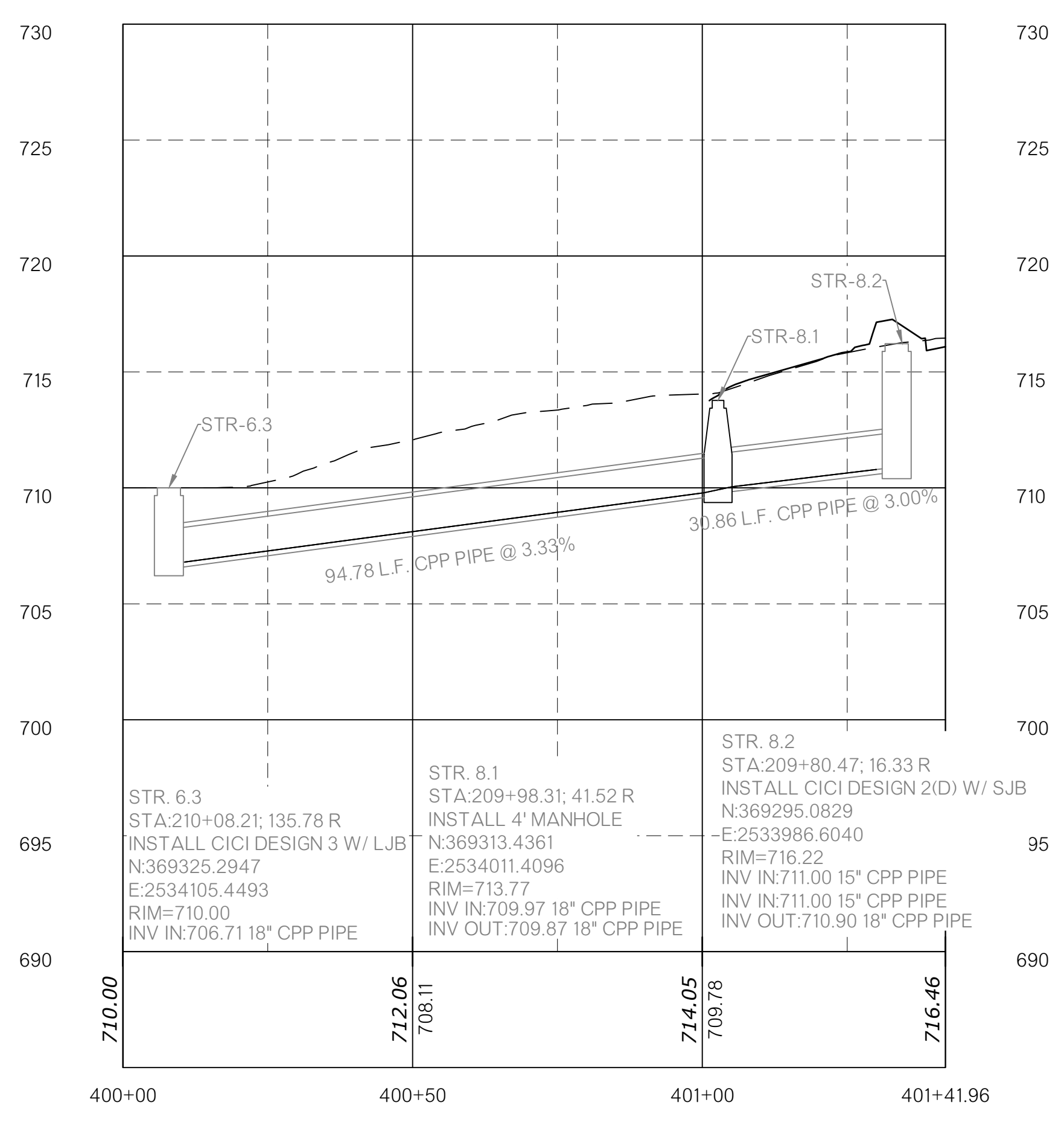
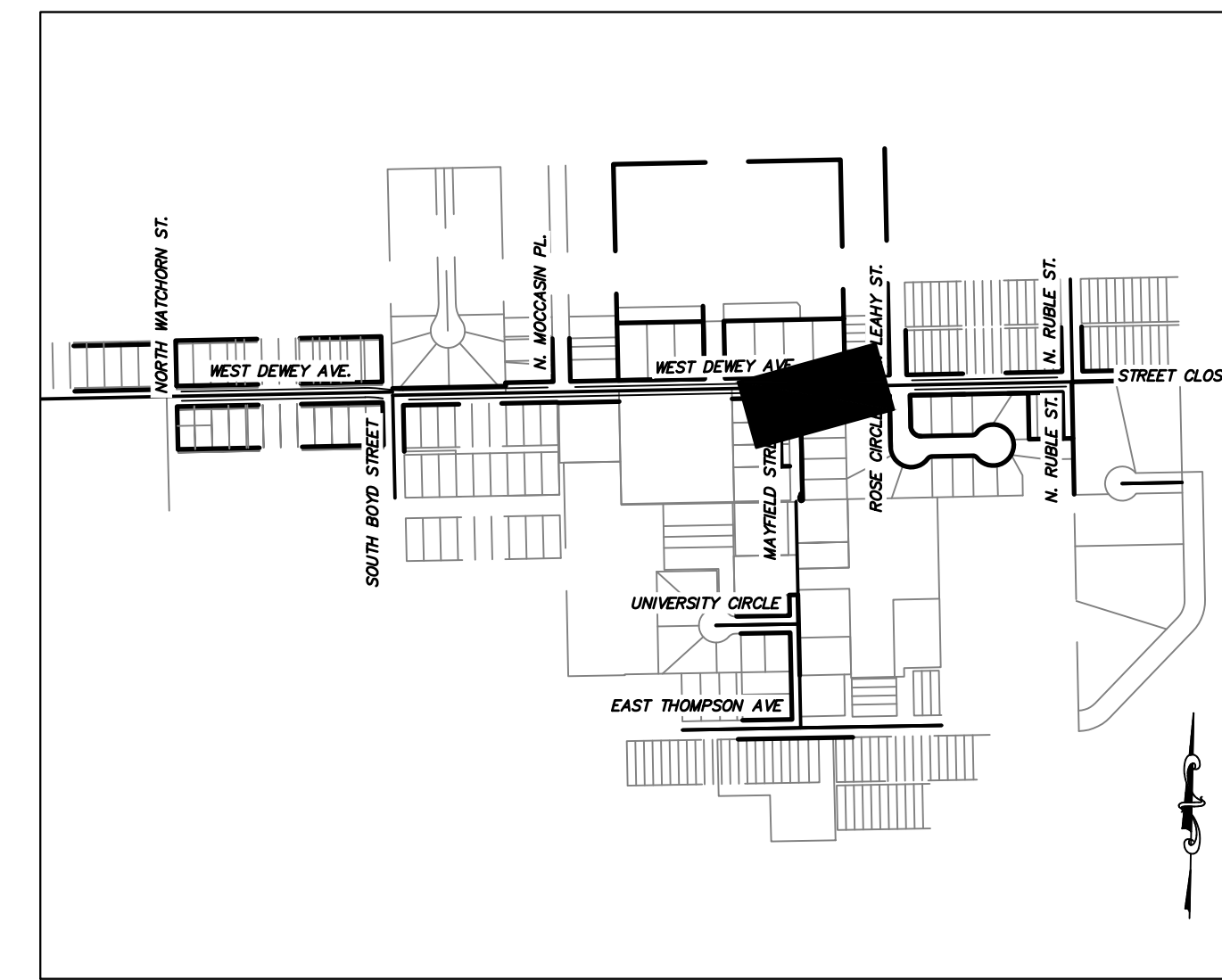
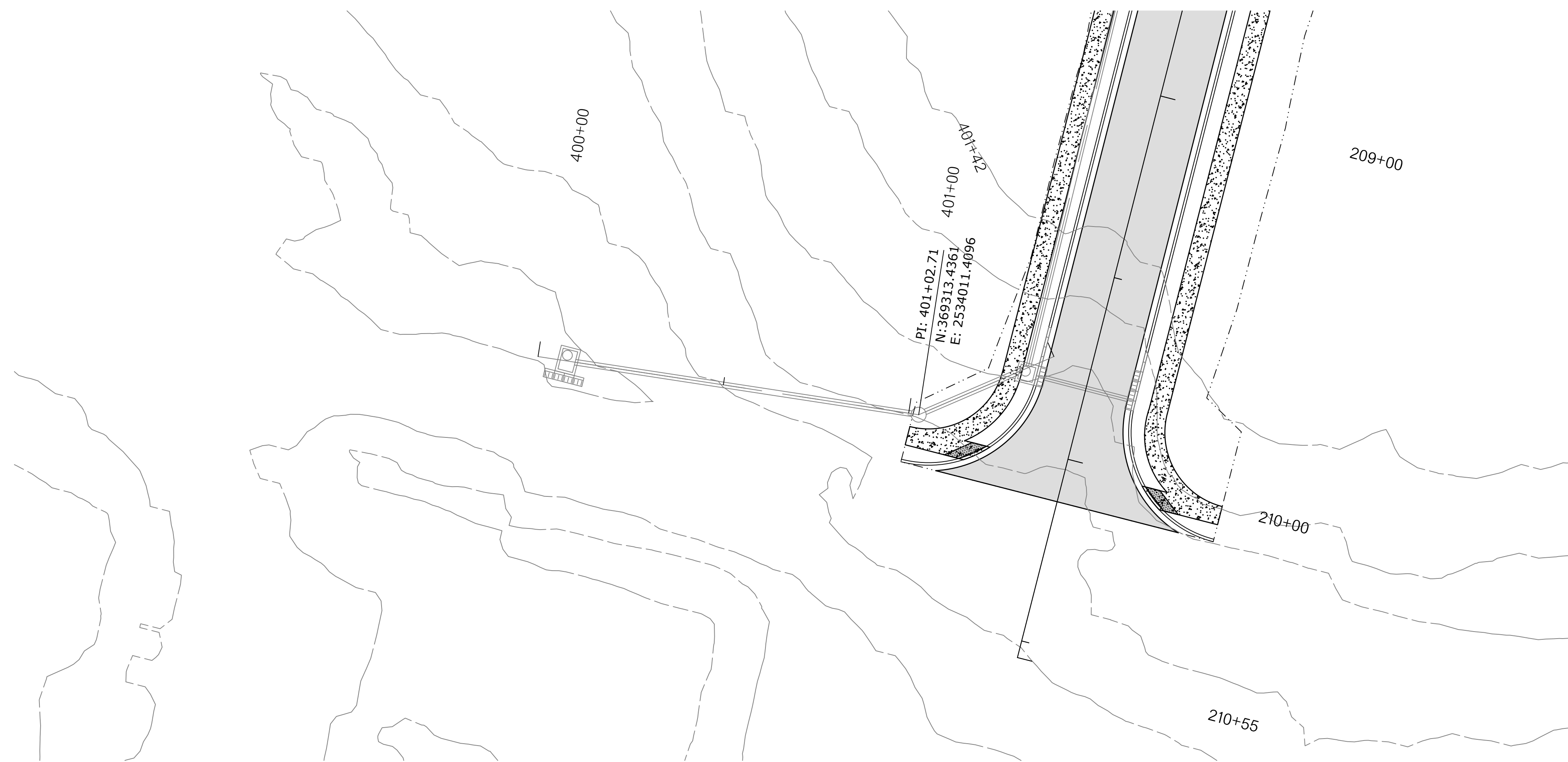

PLOT DATE: 5/3/2022 12:16 AM. DRAWING NAME: 217109 STORM PLAN & PROFILE.DWG

DESIGN	DGR	5/22	OKLAHOMA DEPARTMENT OF TRANSPORTATION
DRAWN	TSS	5/22	
CHECKED	DGR	5/22	
APPROVED	XXX	XX/XX	
SQUAD	<b>ILCE</b>		
COUNTY	CREEK	STREET	

8.1 & 8.2 STORM PIPE  
PLAN & PROFILE



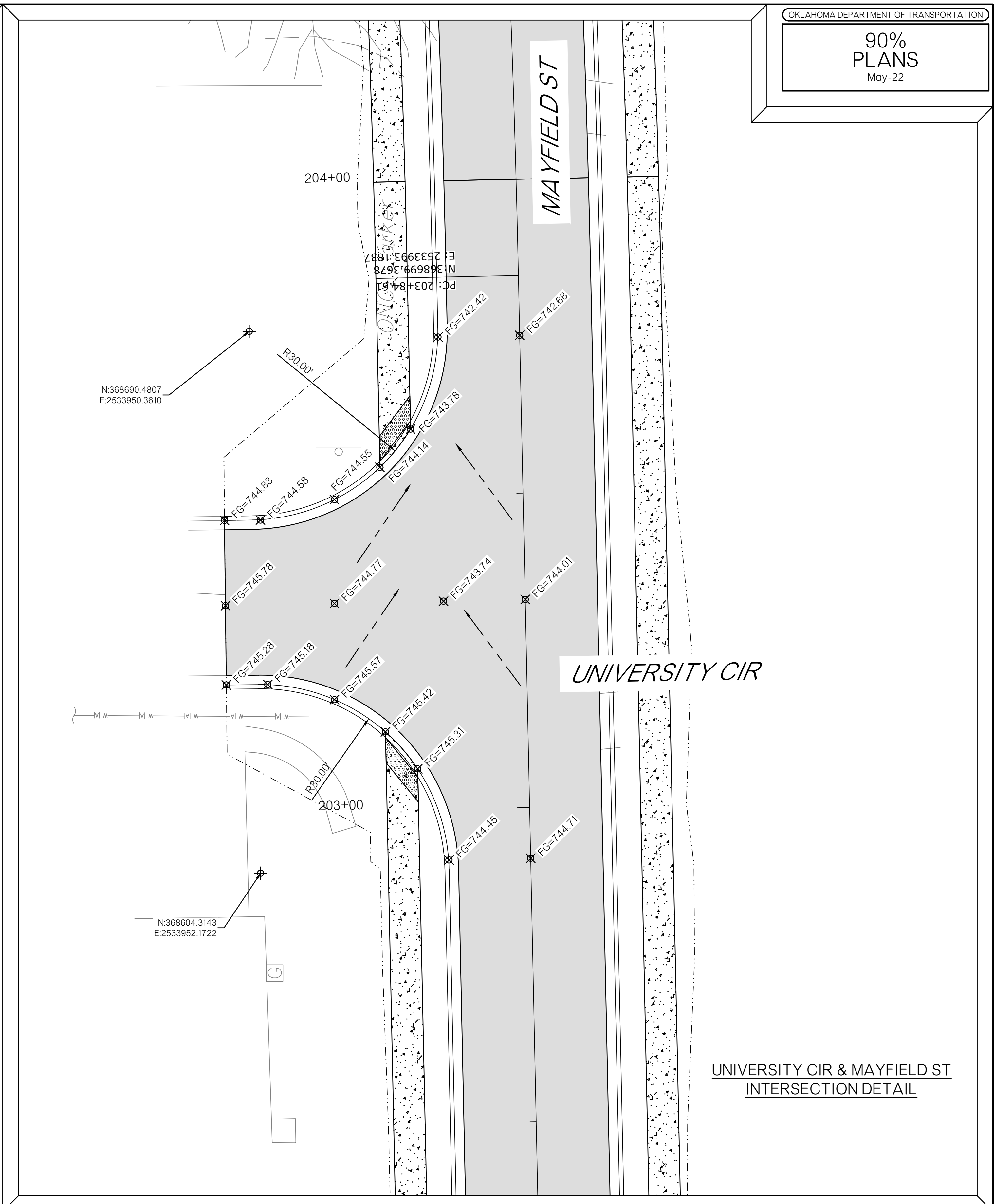
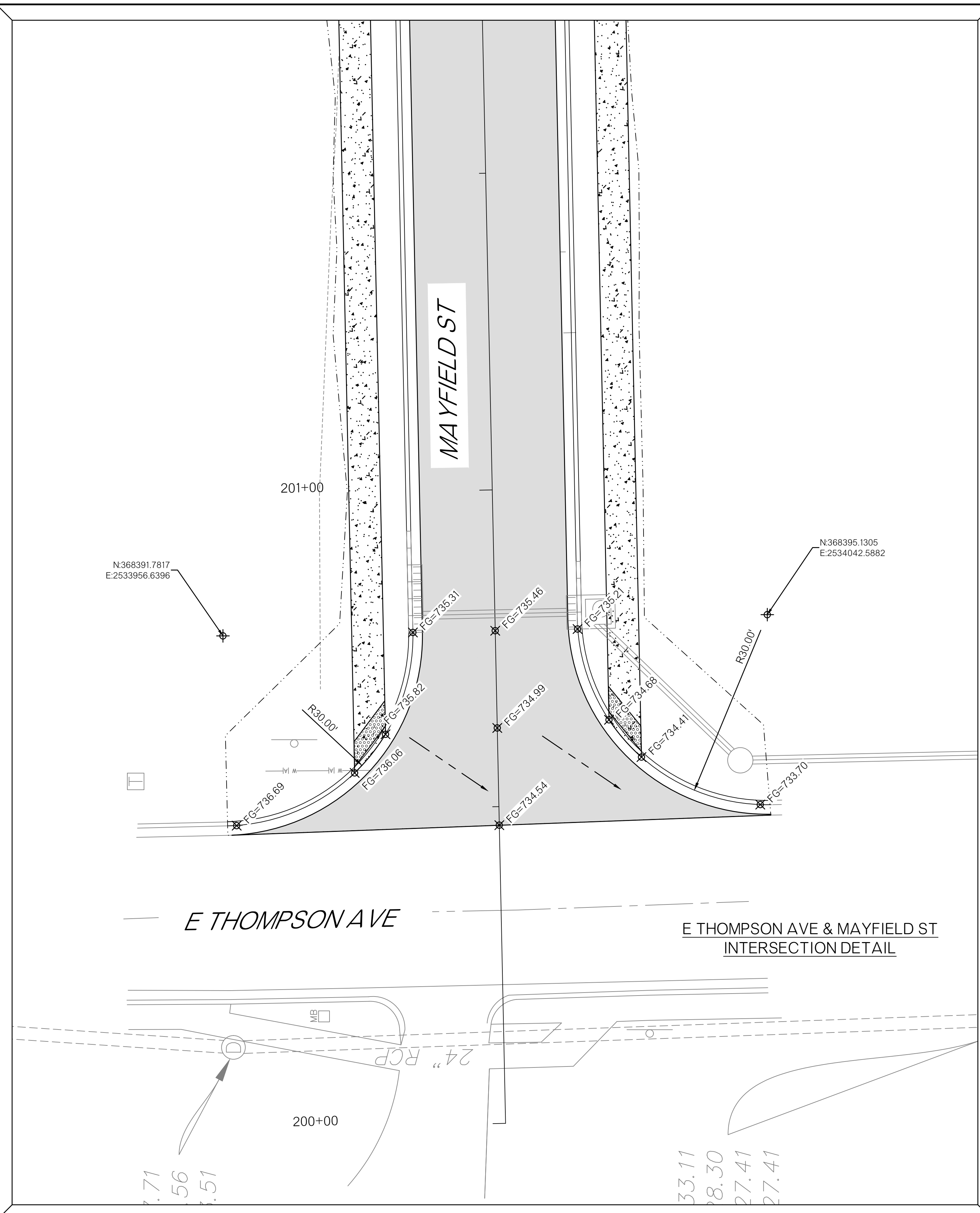

LEGEND

- SURFACE DRAINAGE DIRECTION
- X 687.54 SPOT ELEVATION EXISTING
- ⊗ 687.54 SPOT ELEVATION PROPOSED

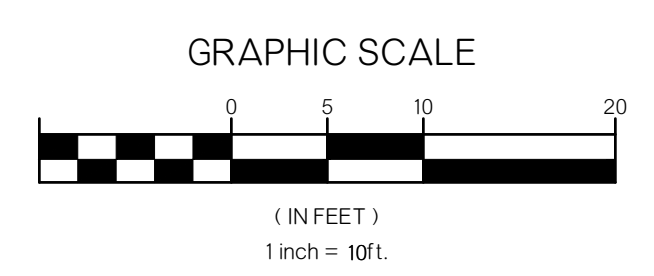

DESIGN	DGR	5/22
DRAWN	TSS	5/22
CHECKED	DGR	5/22
APPROVED	XXX	XX/XX
SQUAD	<b>MCE</b>	

OKLAHOMA DEPARTMENT OF TRANSPORTATION

INTERSECTION DETAIL  
(1 OF 2)

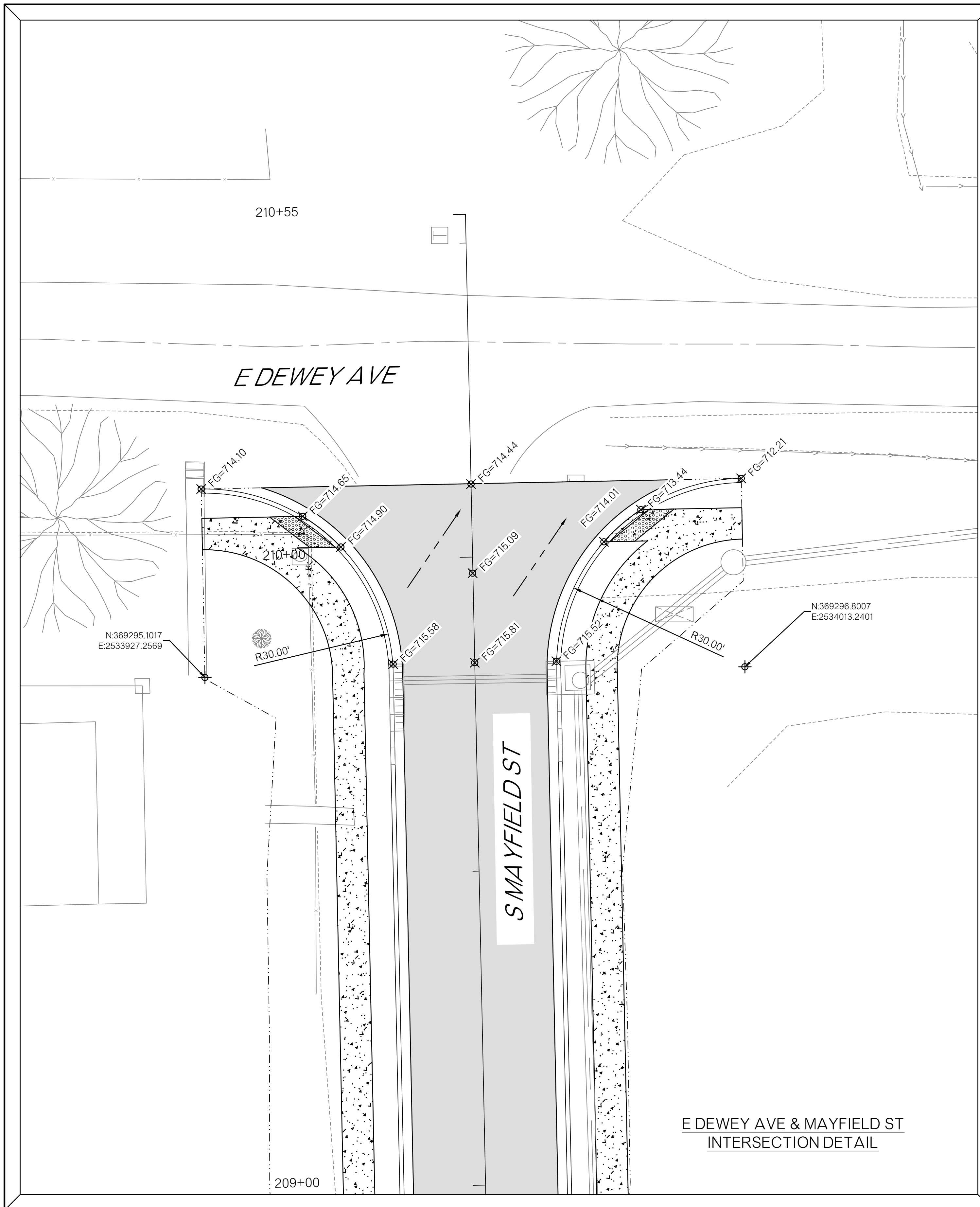

E DEWEY AVE & MAYFIELD ST  
INTERSECTION DETAIL

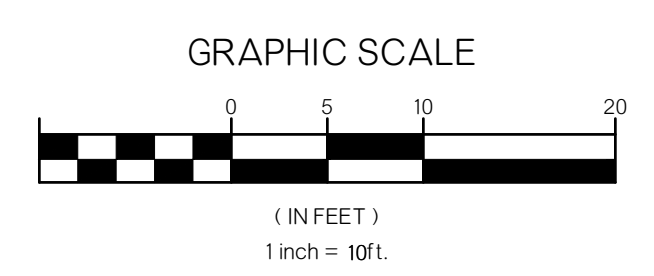

LEGEND

- SURFACE DRAINAGE DIRECTION
- X 687.54 SPOT ELEVATION EXISTING
- ⊗ 687.54 SPOT ELEVATION PROPOSED

DESIGN	DGR	5/22	OKLAHOMA DEPARTMENT OF TRANSPORTATION
DRAWN	TSS	5/22	
CHECKED	DGR	5/22	
APPROVED	XXX	XX/XX	
SQUAD			
COUNTY CREEK STREET MAYFIELD ST STATE JOB NO. N/A SHEET NO. 18			<p>INTERSECTION DETAIL (2 OF 2)</p>

# TOPOGRAPHIC SURVEY FOR STREET IMPROVEMENTS DEWEY AVE. AND MAYFIELD ST. SAPULPA, CREEK COUNTY, OKLAHOMA

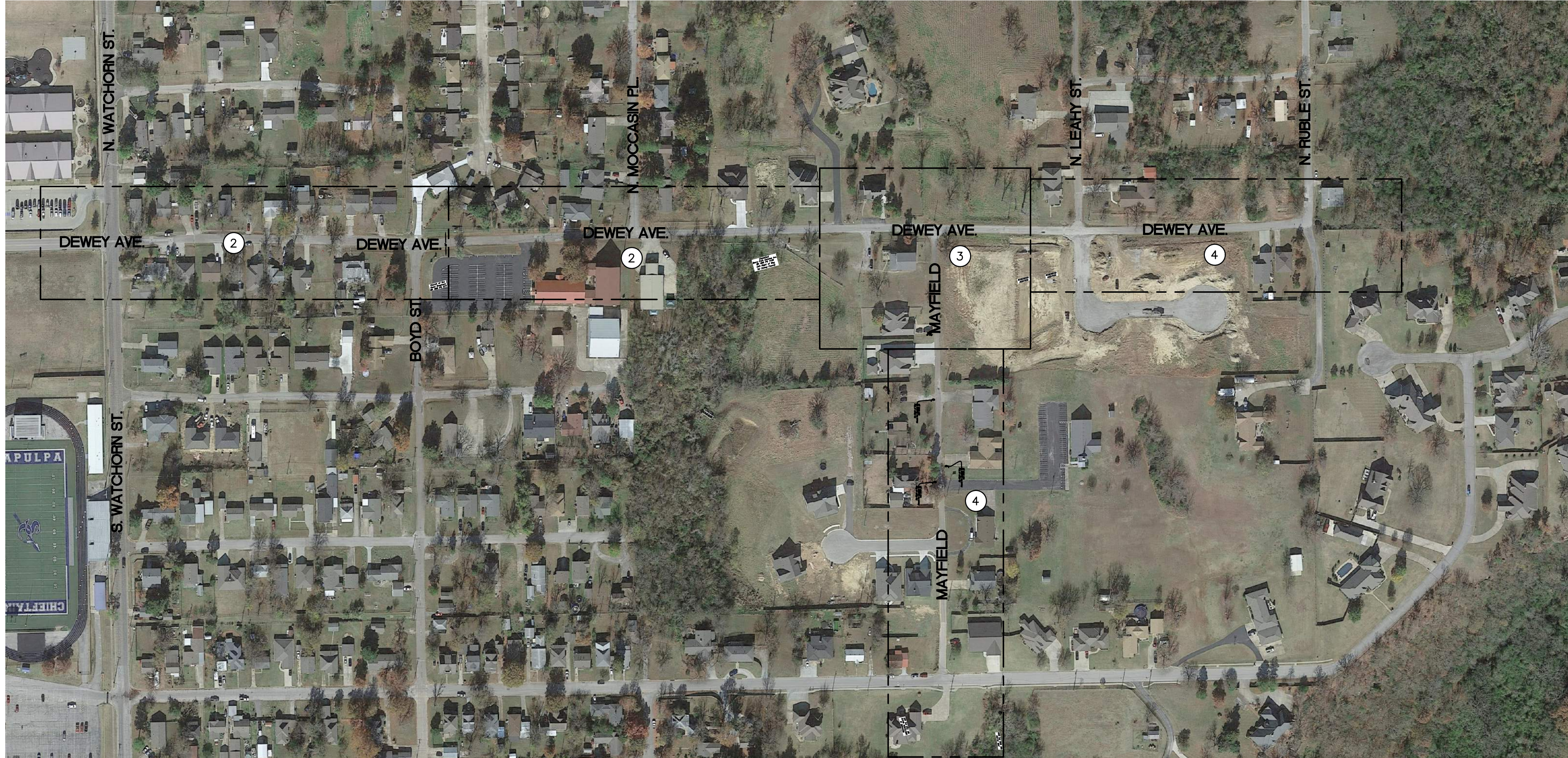

## TOPOGRAPHIC LEGEND

- |       |                             |           |                             |
|-------|-----------------------------|-----------|-----------------------------|
| AC    | AIR CONDITIONER UNIT        | —x—       | BARBED WIRE FENCE           |
| TRA   | GROUND TRANSFORMER          | —o—       | CHAINLINK FENCE             |
| *     | LIGHT POLE                  | —b—       | PIPERAIL FENCE              |
| ⚡     | TRANSFORMER POLE            | —o—       | STOCKADE FENCE              |
| ⊗     | POWER POLE                  | —□□—      | HOG WIRE FENCE              |
| EM    | ELECTRIC METER              | — — —     | EASEMENT                    |
| ↘     | DOWN GUY                    | — · —     | BUILDING SET BACK LINE      |
| TR    | TELEPHONE RISER             | —SS—      | SANITARY SEWER LINE (ATLAS) |
| ALPHA | COMMUNICATIONS BACKUP RISER | — — — —   | STORM DRAIN LINE            |
| GM    | GAS METER                   | —OVT—     | OVERHEAD TELEPHONE LINE     |
| GV    | GAS VALVE                   | —TUG—     | UNDERGROUND TELEPHONE LINE  |
| GS    | GAS VENT                    | —SS—      | SANITARY SEWER LINE         |
| SH    | SPRINKLER HEAD              | — — — —   | OVERHEAD ELECTRIC LINE      |
| SV    | SPRINKLER VALVE             | —1185—    | GROUND SURFACE CONTOUR      |
| ⚡     | FIRE HYDRANT                | — — — —   | CURB AND GUTTER             |
| CV    | COMMUNICATIONS VAULT        | — · · · — | SURFACE DRAINAGE FLOWLINE   |
| SM    | SANITARY SEWER MANHOLE      | — — — —   | TREE DRIP LINE              |
| SSC   | SANITARY SEWER CLEANOUT     | — — — —   | SHRUB LINE                  |
| SSL   | SANITARY SEWER LAMPHOLE     | — — — —   | WATER LINE                  |
| SDM   | STORM DRAIN MANHOLE         | — — — —   | WATER LINE (ATLAS)          |
| WM    | WATER METER                 | — — — —   | CONCRETE                    |
| WVB   | WATER VALVE BOX             | — — — —   | ASPHALT                     |
| GP    | GUARD POST                  | — — — —   | GRAVEL                      |
| MB    | MAILBOX                     |           |                             |
| FP    | FLAG POLE                   |           |                             |
| S     | SIGN                        |           |                             |

## SURVEYOR'S NOTES

- In McAllister Addition and in Forest Park addition, different sets of monumentation were found. The blue lines represent the blocks of 1 set of found monumentation, the red lines represent the block of a 2nd set of monumentation, and the black lot/block lines represent the monumentation found throughout Dewey Avenue and extended west.
- Along Mayfield Street, there were properties where no Right-of-Way documentation was found. It appears Mayfield Street may be lacking some road Right-of-Way.
- This survey was prepared without the benefit of a Title Commitment, Title Opinion, or Abstract as none were provided to the surveyor. Although a due diligence search for easements and items affecting the property was performed, there may be items that affect the subject property that are not shown hereon.
- Basis of Bearings is Grid Oklahoma State Plane Coordinate System (NAD83) North Zone (3501).
- Utilities were located using visible evidence, city atlas maps (where available) and markings/flags by an Okie-811 call. There may be underground utilities that are not shown hereon. CALL 811 BEFORE DIGGING!
- All points were located with RTK Observations in U.S. survey feet unless an assumed coordinate system was used and noted hereon. All field measurements and angles applied to control points were made with a Leica GS-15 and a Leica TS-15 Robotic Total Station.
- All elevations of control points are based on initial elevation of LLS 100 and the datum used is NAVD88. All elevations of control points are determined by and Sokkia Bar-code Reading Automatic Level or Robotic Total Station to practice accuracy standards unless otherwise noted.
- This survey was performed to meet the Specifications for Topographic and Planimetric Mapping contained in the Oklahoma Minimum Standards for the Practice of Land Surveying as adopted by the Oklahoma State Board of Licensure for Professional Engineers and Land Surveyors unless a more stringent level of accuracy was requested. The original data was obtained between 07-19-2021 and 08-27-2021.
- Points designated as "Control Points" should be used for horizontal coordinate control and should be checked to a published site Benchmark for vertical accuracy.
- Points designated as "Benchmark" should be used for vertical elevations, and unless otherwise specified or noted, should not be used for horizontal positioning.

## SURVEY CONTROL

ON SITE HORIZONTAL AND VERTICAL CONTROL				
POINT #	NORTHING	EASTING	ELEVATION	DESCRIPTION
LLS 100	369334.214	2532091.370	723.99	SET #4 BAR W/ CAP LEMKE CONTROL
LLS 101	369301.515	2532690.121	729.45	SET #4 BAR W/ CAP LEMKE CONTROL
LLS 102	369301.740	2533128.269	730.52	SET #4 BAR W/ CAP LEMKE CONTROL
LSS 103	369352.516	2533495.476	706.53	SET #4 BAR W/ CAP LEMKE CONTROL
LLS 104	369321.868	2533944.995	716.66	SET #4 BAR W/ CAP LEMKE CONTROL
LLS 105	369336.969	2534767.529	728.52	SET #4 BAR W/ CAP LEMKE CONTROL
LLS 106	368996.285	2533995.444	733.26	SET #4 BAR W/ CAP LEMKE CONTROL
LLS 107	368548.198	2533968.652	744.76	SET #4 BAR W/ CAP LEMKE CONTROL
ON SITE BENCHMARK				
LLS 1	369300.11	2532105.52	724.74	CUT "X" ON TOP OF CONCRETE STORM STR.
HORIZONTAL DATUM: OKLAHOMA STATE PLANE COORDINATE SYSTEM NAD83 NORTH ZONE 3501				
VERTICAL DATUM NAVD88				

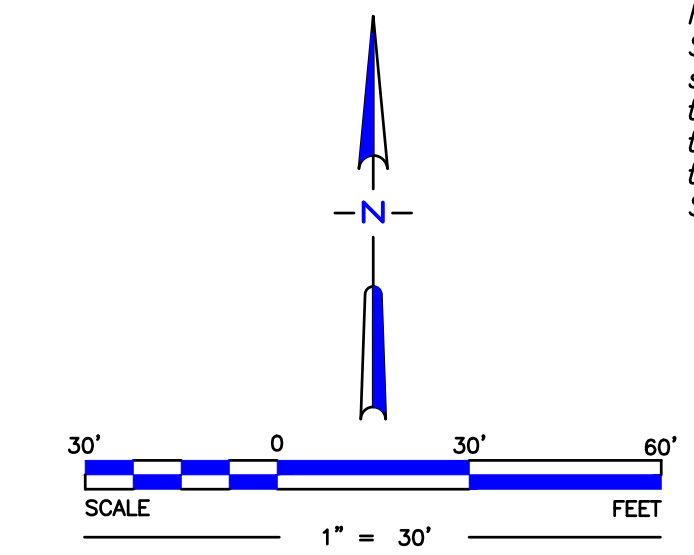
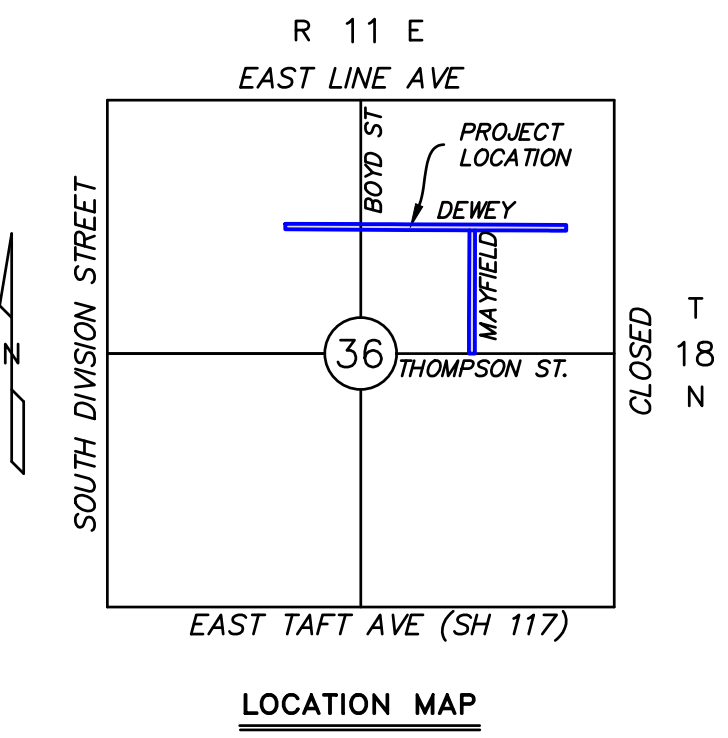

## SURVEYOR'S CERTIFICATION:

I, Charles D. Cahill, Professional Land Surveyor No. 1470 in and for the State of Oklahoma, do hereby certify that I or those under my direct supervision have performed a careful topographic survey as shown by the annexed plat. I further certify that this survey meets or exceeds the Oklahoma Minimum Standards for Land Surveying as adopted by the Oklahoma State Board of Registration for Engineers and Land Surveyors.

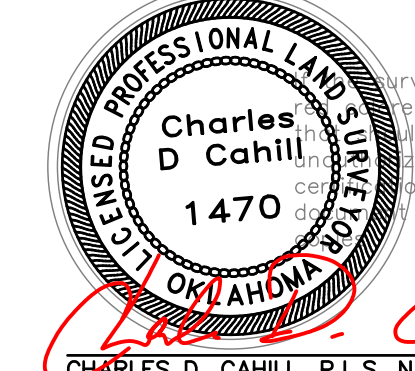

DATE OF LAST SURVEY: 08/27/2021  
DATE: 09/14/2021

**UTILITY WARNING:**  
The underground utilities shown have been located from record documents or field locations by the operator. The surveyor makes no guarantee that the underground utilities shown comprise all such utilities in the area either in service or abandoned. The surveyor further does not warrant that the underground utilities shown are in the exact location indicated although the surveyor does certify that they are located as accurately as possible from the information available. The surveyor has not physically located the underground utilities.

Utility elevations and sizes may have been measured under adverse field conditions. Upon exposing the utility, elevations and line sizes should be verified by the contractor prior to construction. Contractor should verify critical elevations using the benchmark provided by the surveyor or engineer. Any discrepancies should be immediately brought to the engineer's and surveyor's attention.

Call OKIE Ticket Nos. 21072615585132 ~ 21072615595139 ~ 21072616105206 ~ 21072616185259 ~ 21072616275298 ~ 21072616305313 ~ 21072616305313 ~ 21072616305318 ~ 21072616365348 ~ 21072616365352

**MEMBERS NOTIFIED:**

500377	USIC/Cox Comm/Tulsa	500445	USIC/ONG/EAST OK
101506	USIC/OG&E/Sapulpa	T11158	A7&T Distribution
110267	Sapulpa City Of 110267		



LEMKE LAND SURVEYING  
1400 S. W. 10th St., Tulsa, OK 74106  
Phone: (918) 438-1111 Fax: (918) 438-1112  
www.lemkeland.com

<p>Surveyed By: RLR/JL/ER Drawn By: RLR Approved By: CDC Date: 09/15/2021 Scale: 1" = 30' Project No: 01614121-00</p>	<p>TOPOGRAPHIC DESIGN SURVEY DEWEY AVENUE AND MAYFIELD STREET DEWEY AVENUE AND MAYFIELD STREET CITY OF SAPULPA, CREEK COUNTY, STATE OF OKLAHOMA McCLELLAND CONSULTING ENGINEERS INC., 4606 SOUTH GARNETT ROAD STE 401, TULSA, OK 74146</p>
<p>Sheet Number <b>19</b> Sheet 1 of 4</p>	<p>Mark</p>

Date	Aspr.

Surveyed By:	RLR/UL/ER
Drawn By:	RLR
Approved By:	CDC
Date:	09/15/2021
Scale:	1" = 30'
Project No:	01614121.00

TOPOGRAPHIC DESIGN SURVEY  
DEWEY AVENUE AND MAYFIELD STREET IMPROVEMENTS  
DEWEY AVENUE AND MAYFIELD STREET  
CITY OF SAPULPA, CREEK COUNTY, STATE OF OKLAHOMA  
McCLELLAND CONSULTING ENGINEERS, INC.  
4606 SOUTH GARNETT ROAD STE 401, TULSA, OK 74146

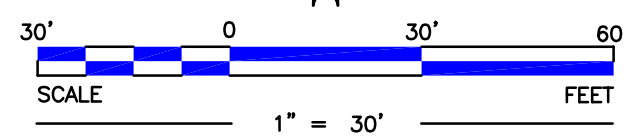
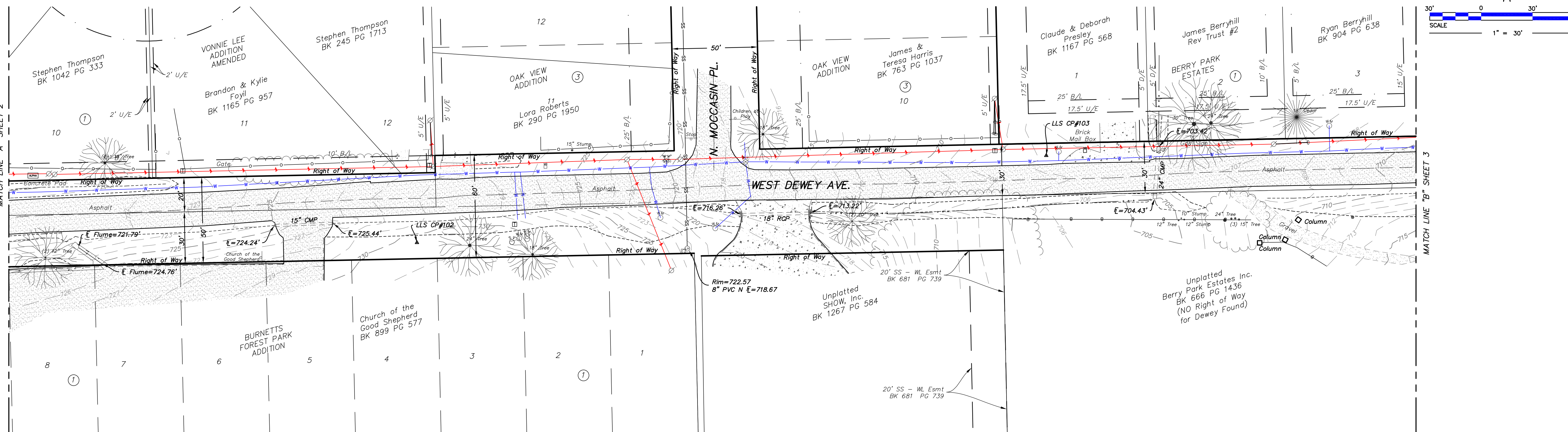
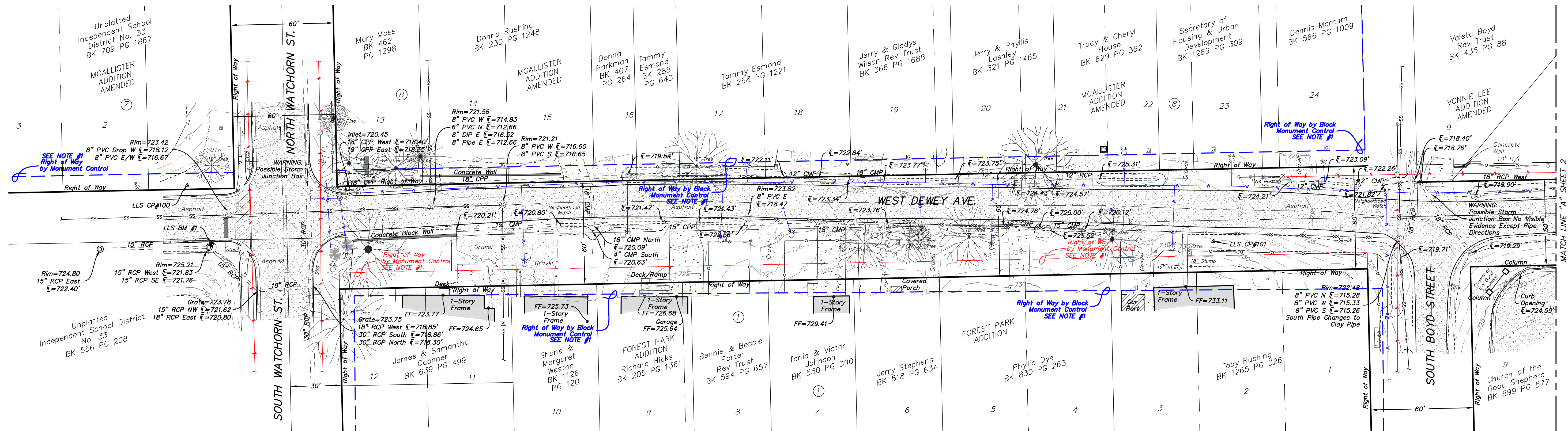

Date	Appr.

Surveyed By:	RLR/JL/ER
Drawn By:	RLR
Approved By:	CDC
Date:	09/15/2021
Scale:	1" = 30'
Project No.:	01614121.00

Project:
DEWEY AVENUE AND MAYFIELD STREET IMPROVEMENTS
DEWEY AVENUE AND MAYFIELD STREET
CITY OF SAPULPA, CREEK COUNTY, STATE OF OKLAHOMA
McCLELLAND CONSULTING ENGINEERS INC.,
4606 SOUTH GARNETT ROAD STE 401, TULSA, OK 74146

Sheet Number
<b>21</b>

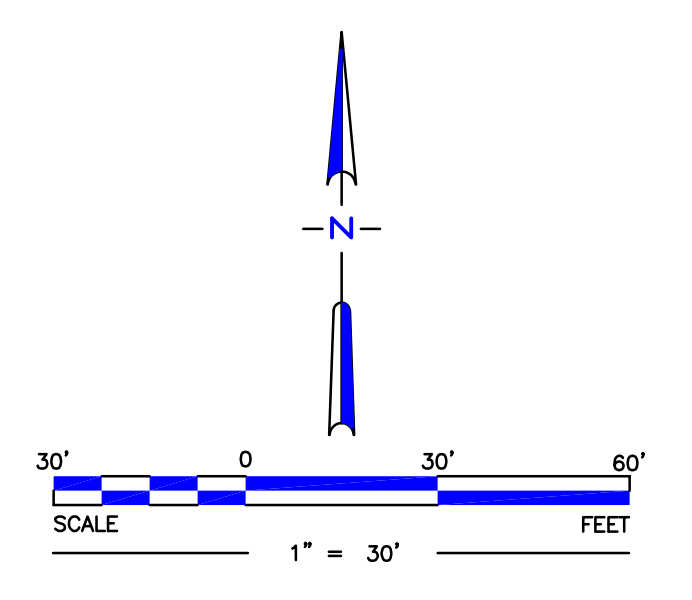
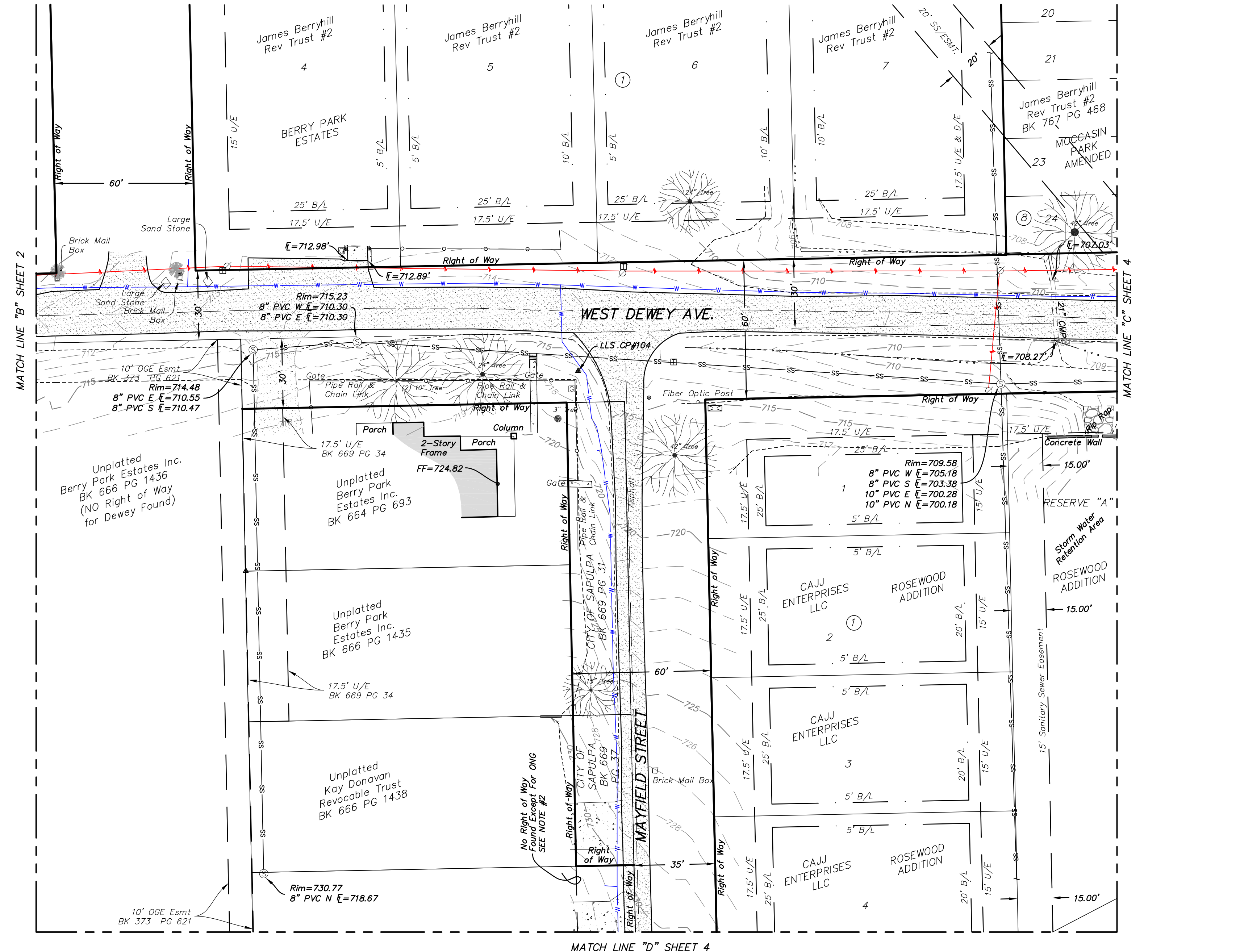

C:\Projects\01614121.00\_McClelland & Berryhill\Drawings\05-OKIEY AND MAYFIELD\_032021.dwg, 8/15/2021, 10:00:29 AM



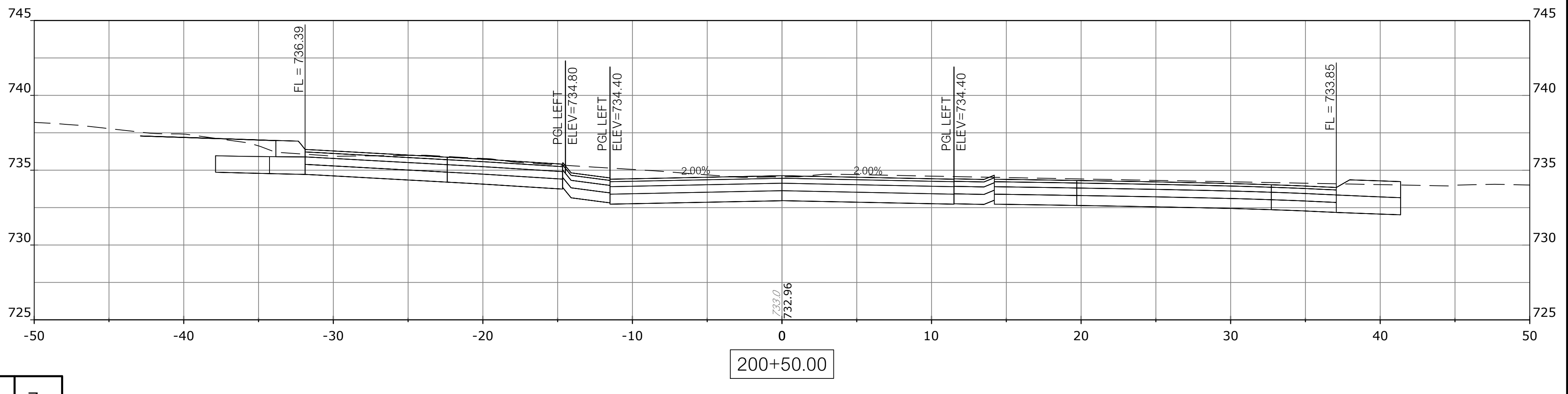
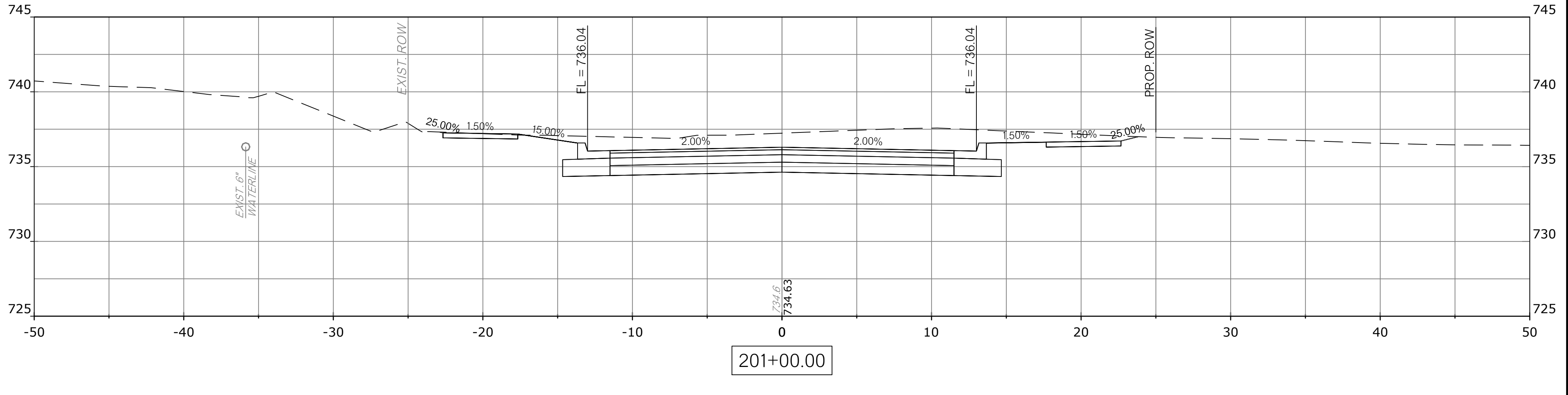
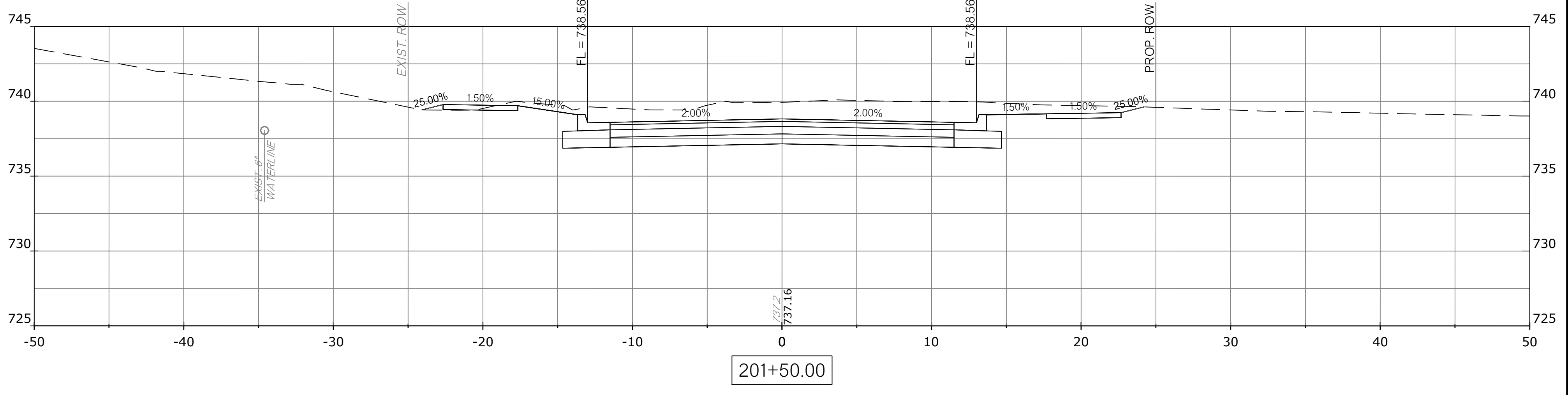
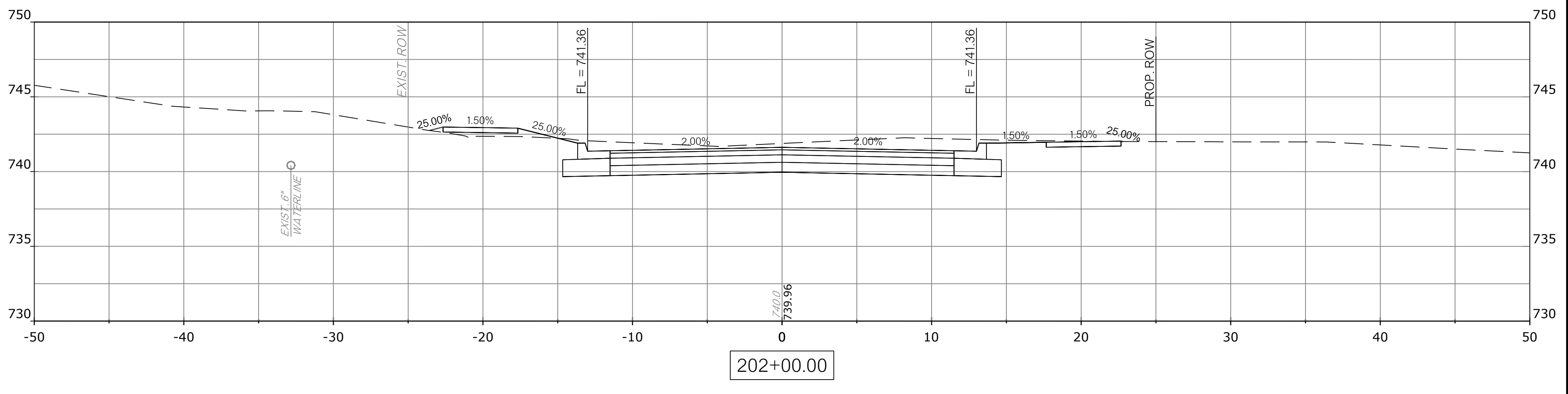
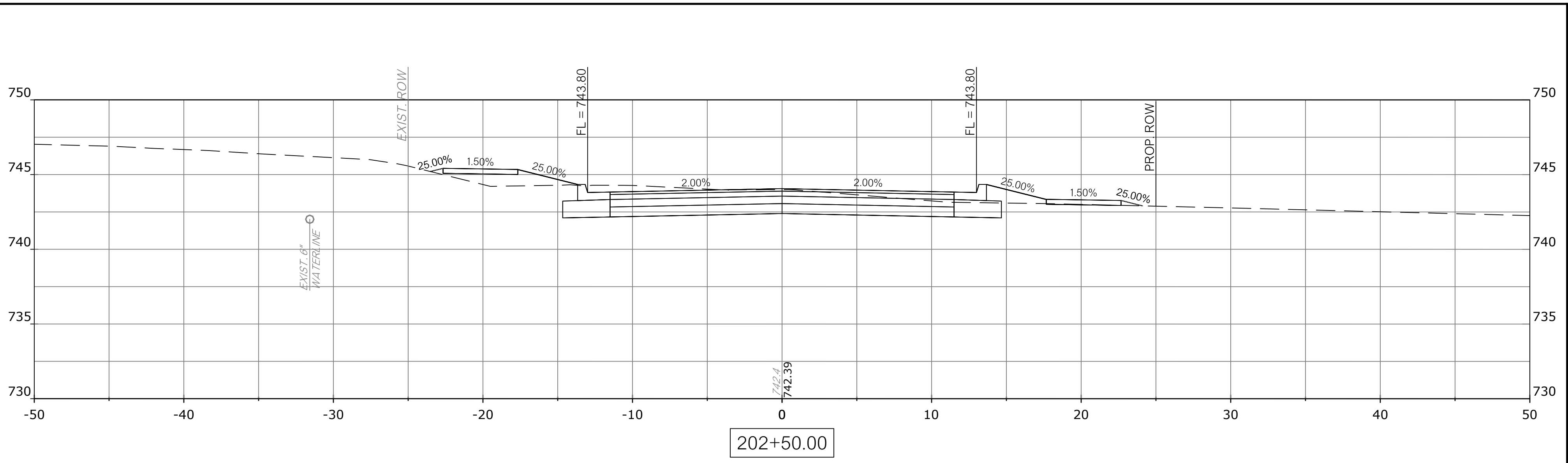

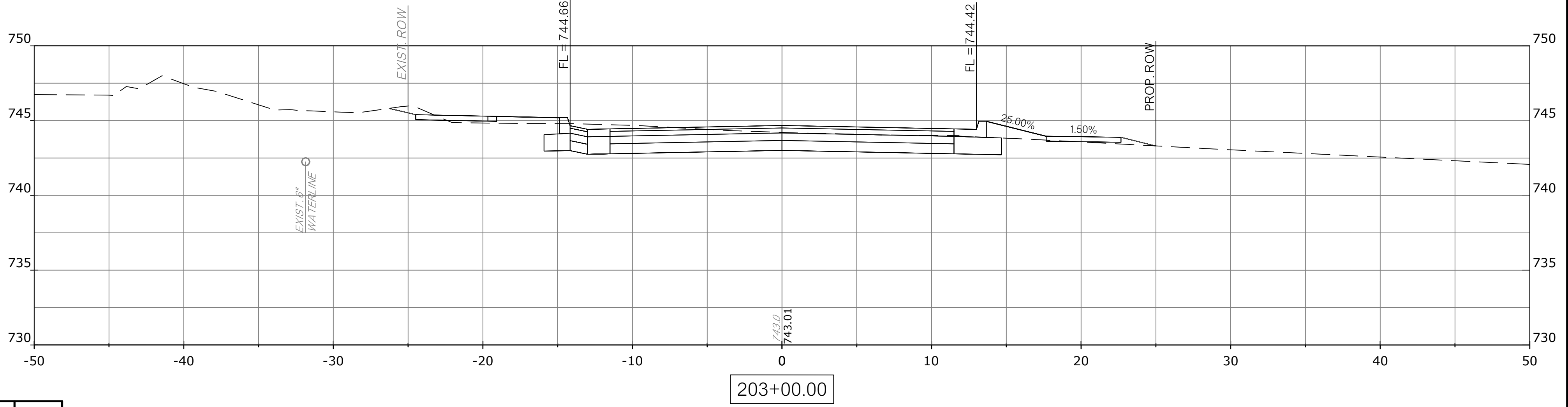
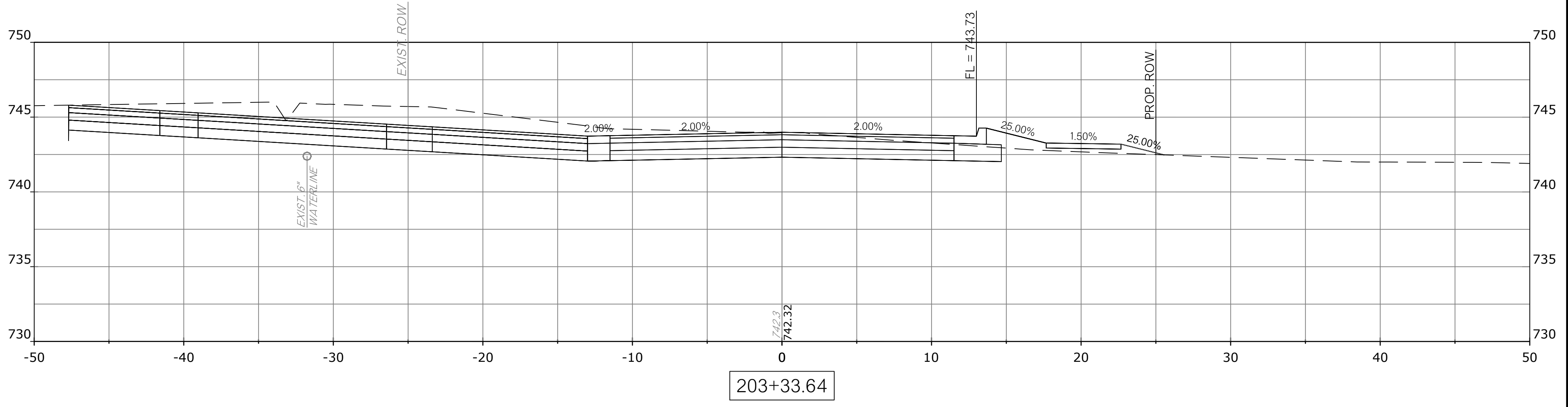
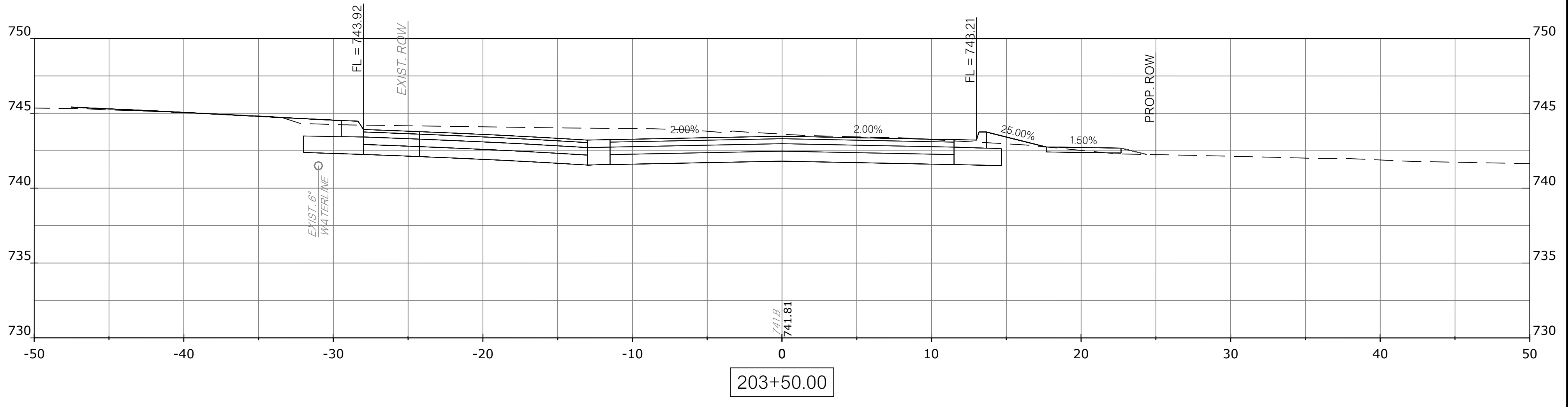
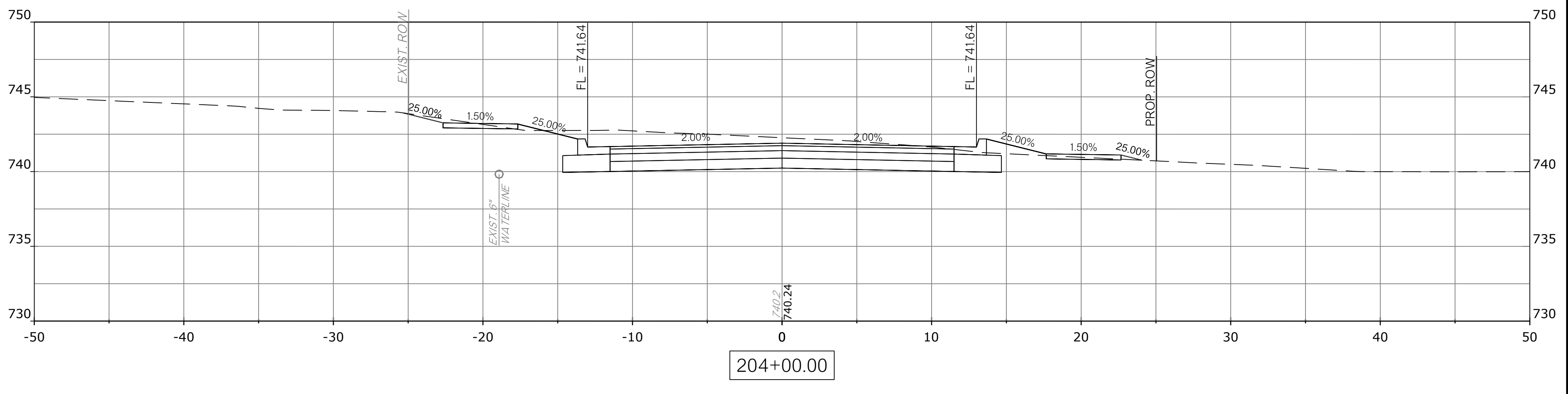
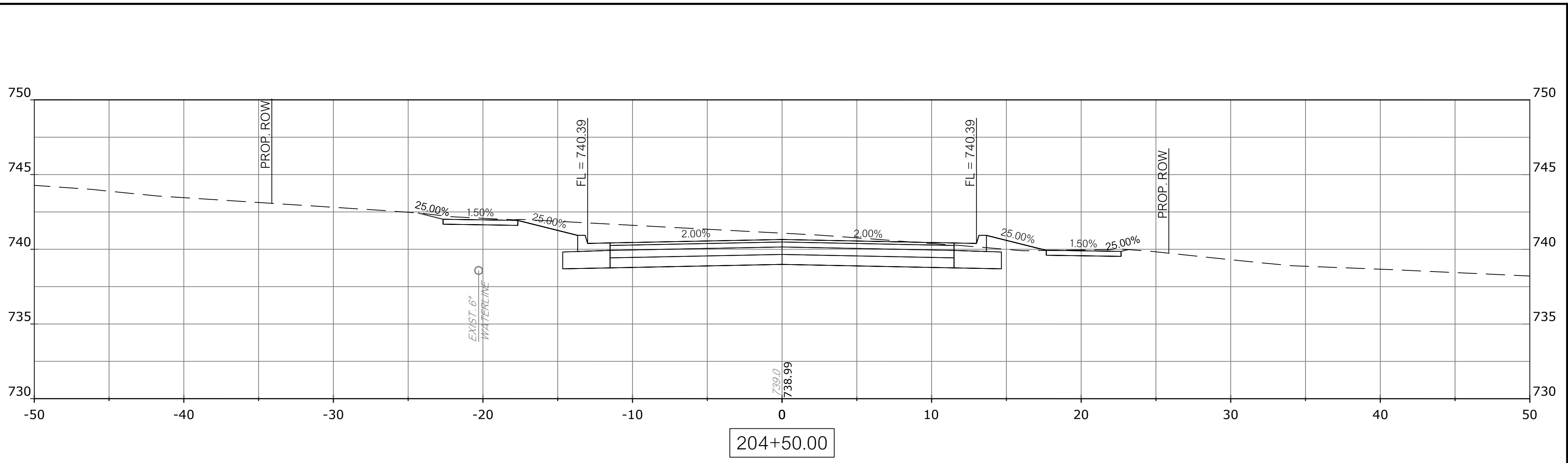



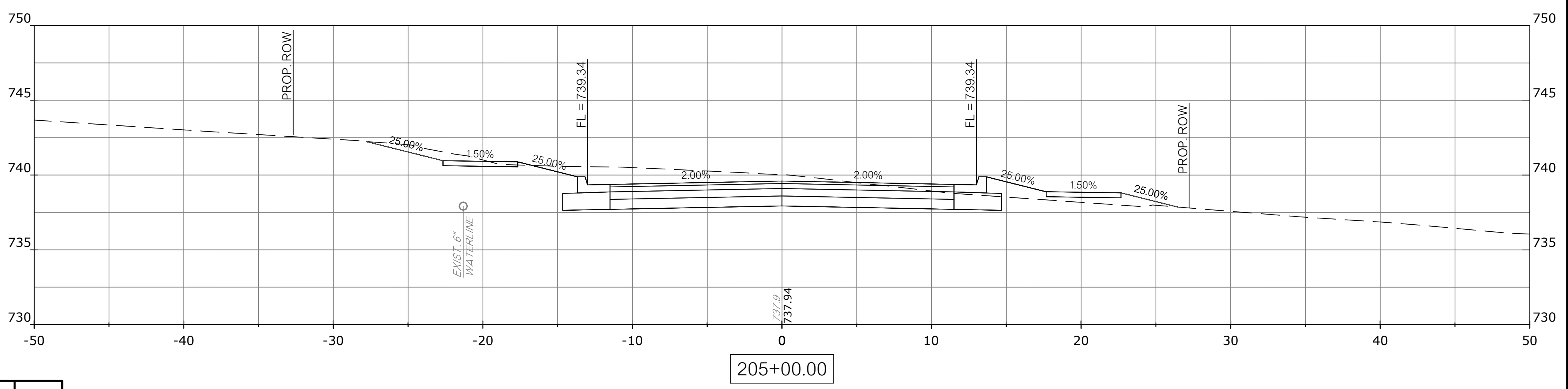
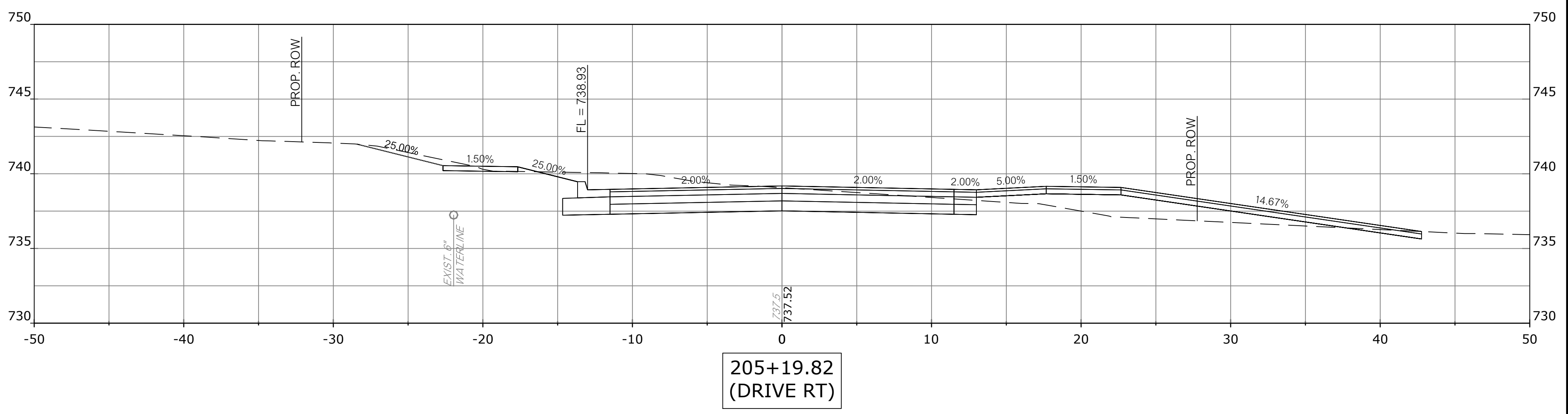
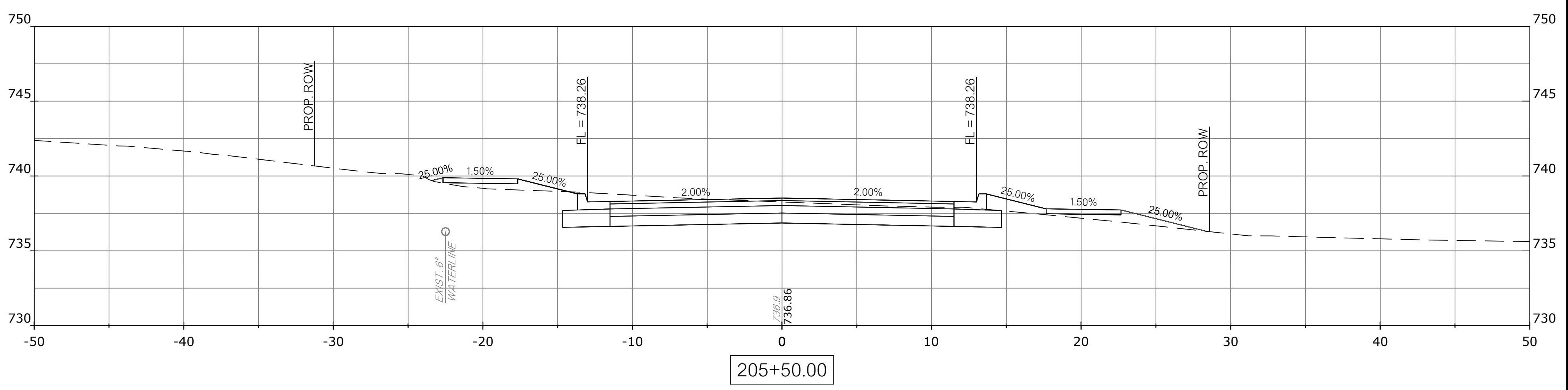
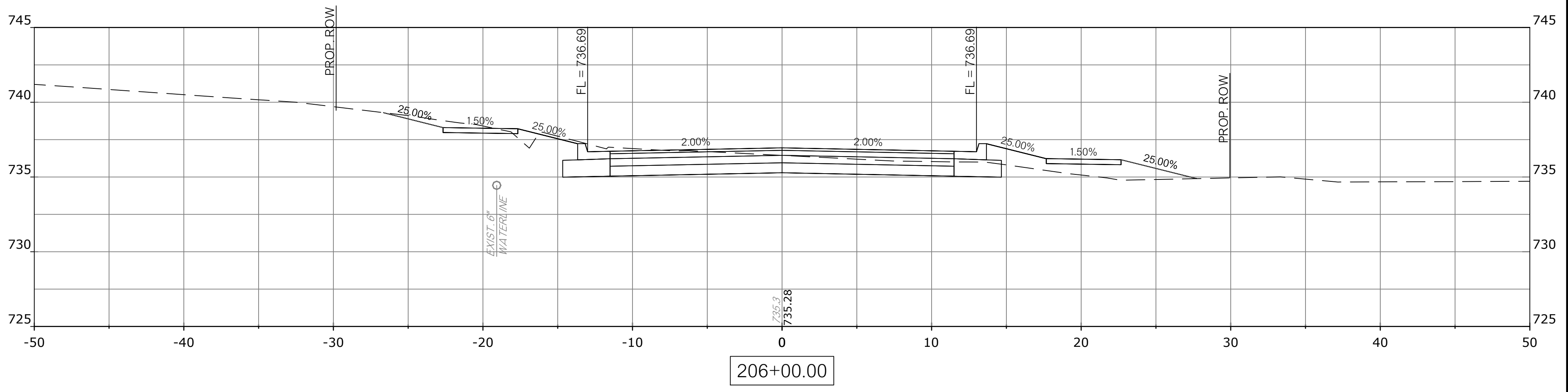
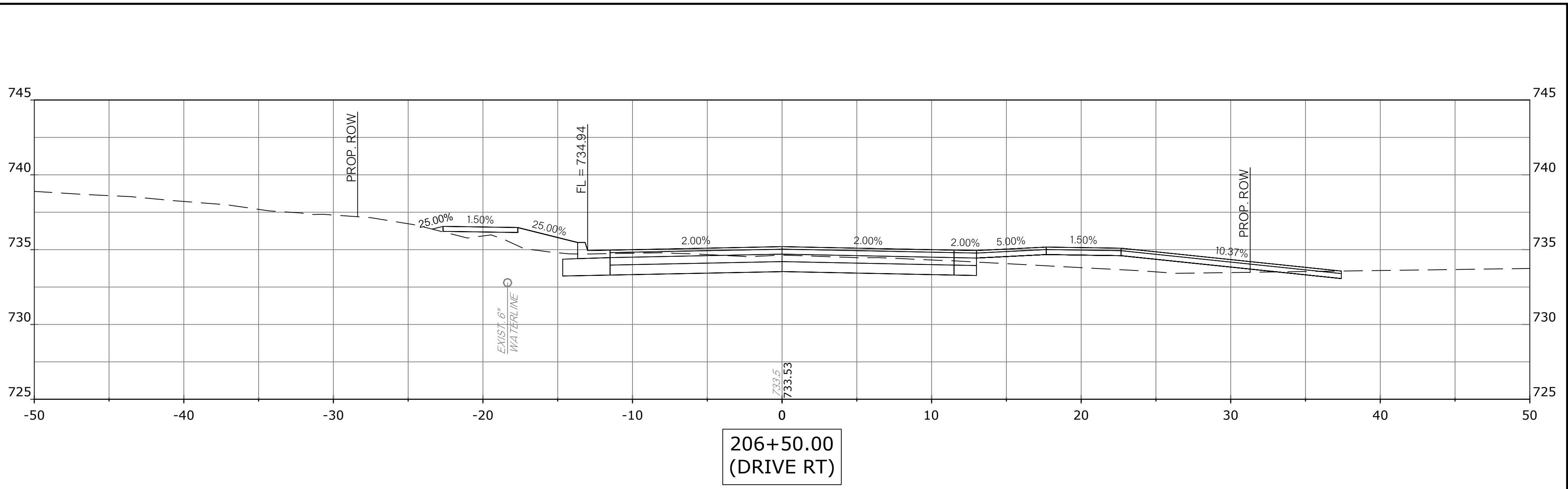

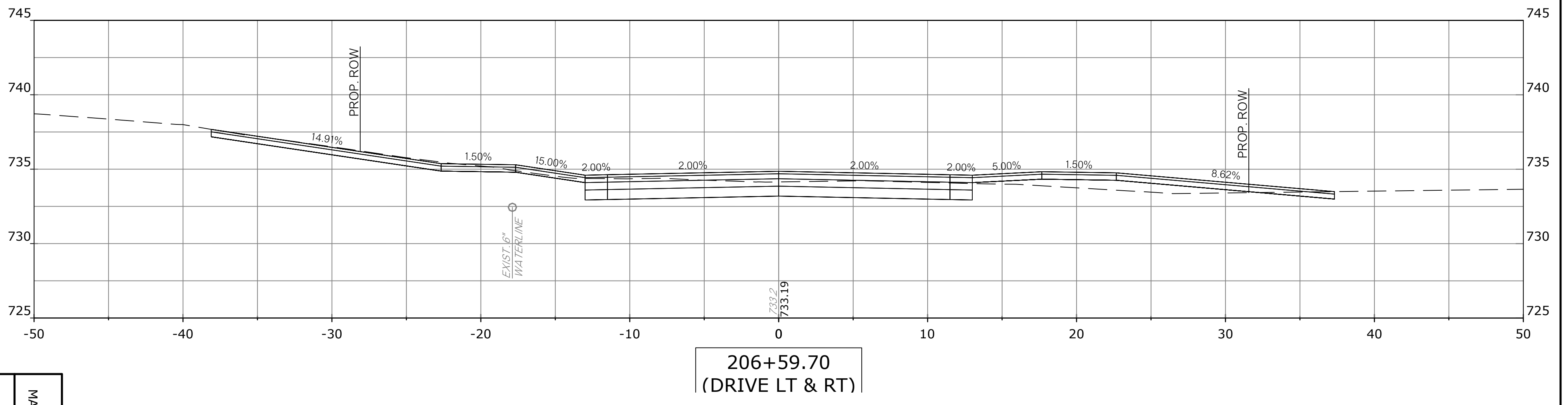
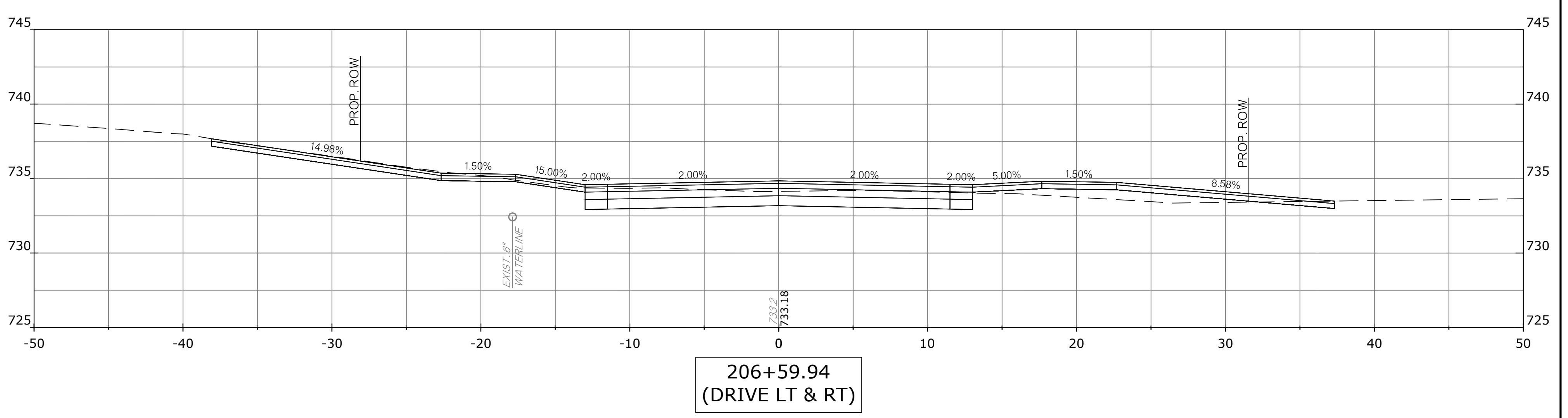
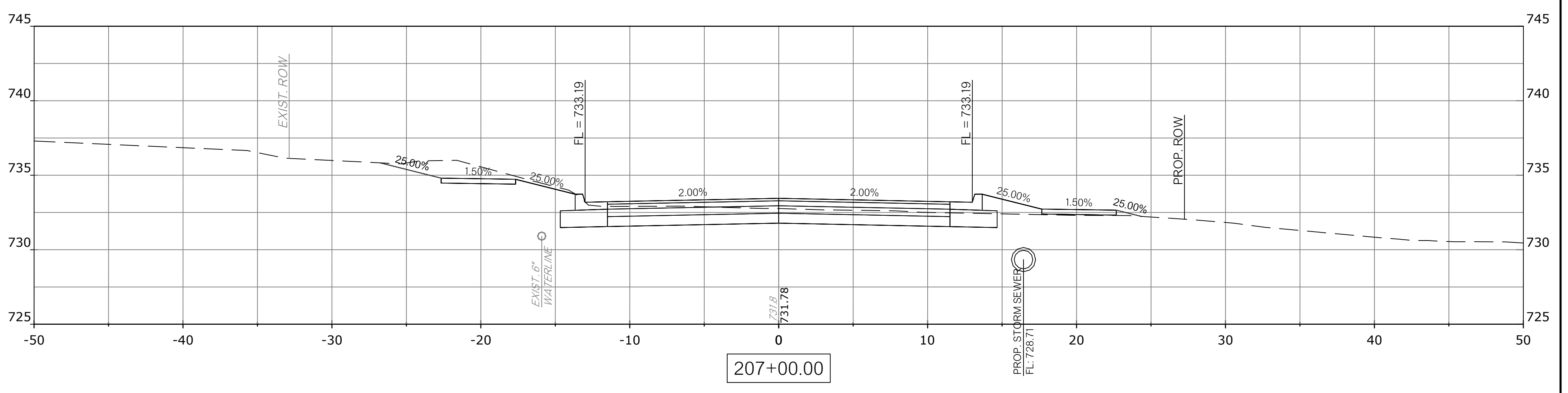
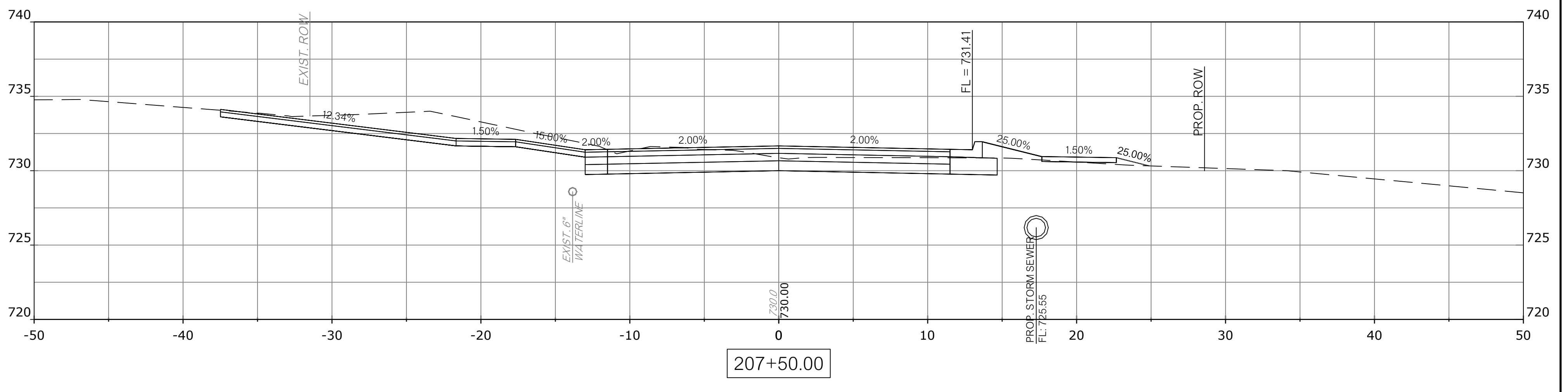
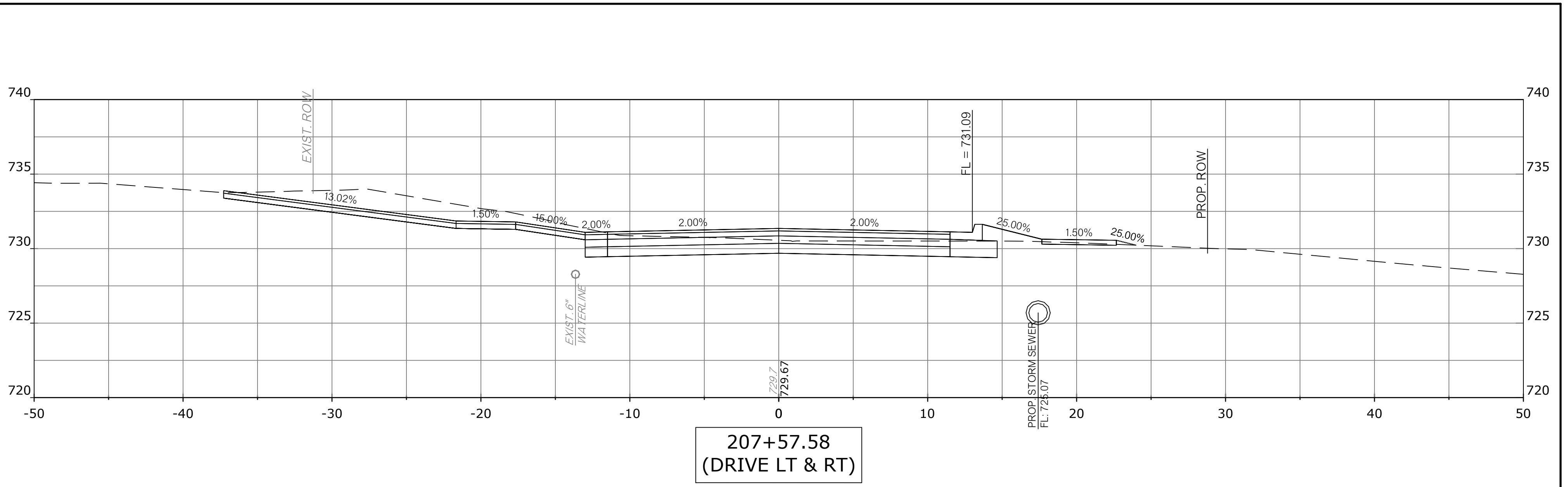

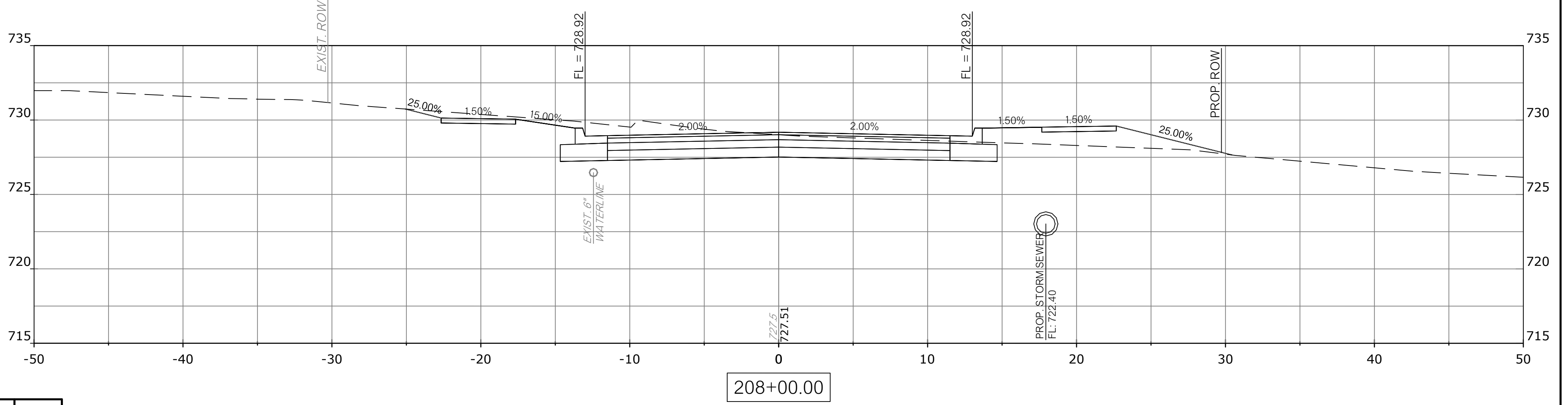
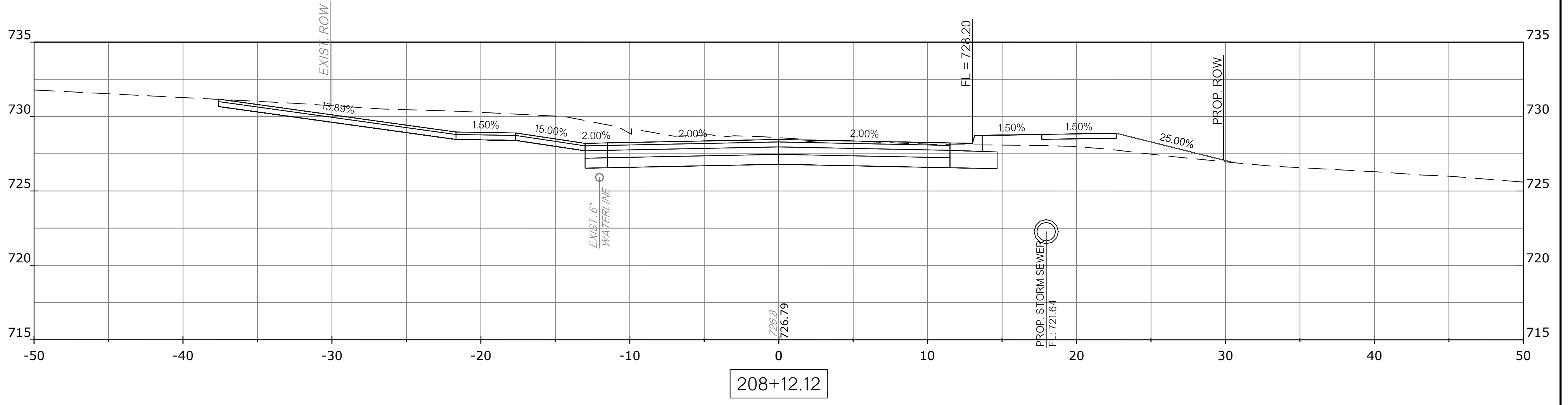
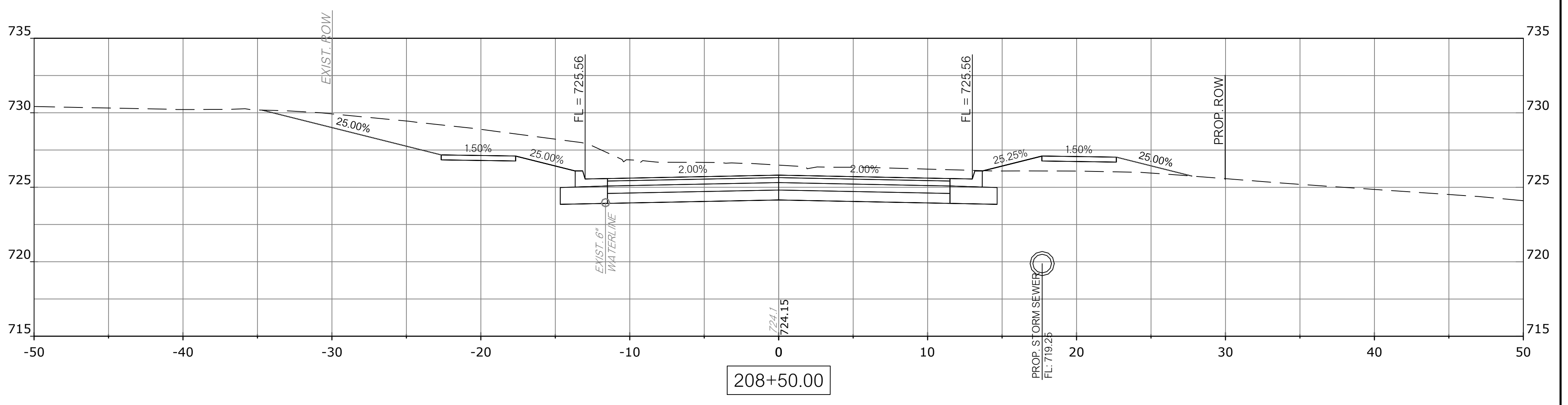
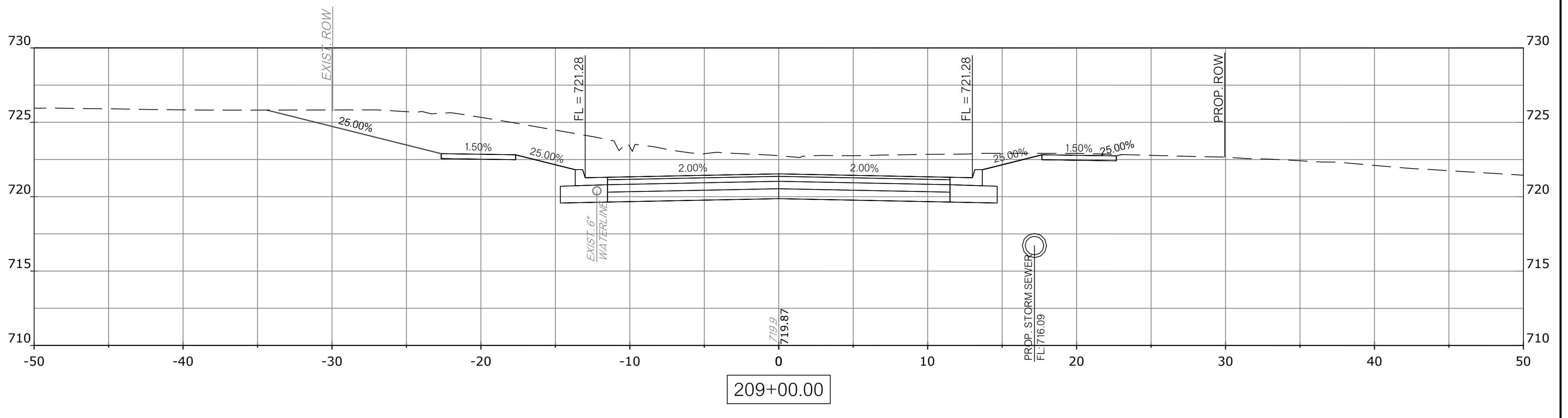
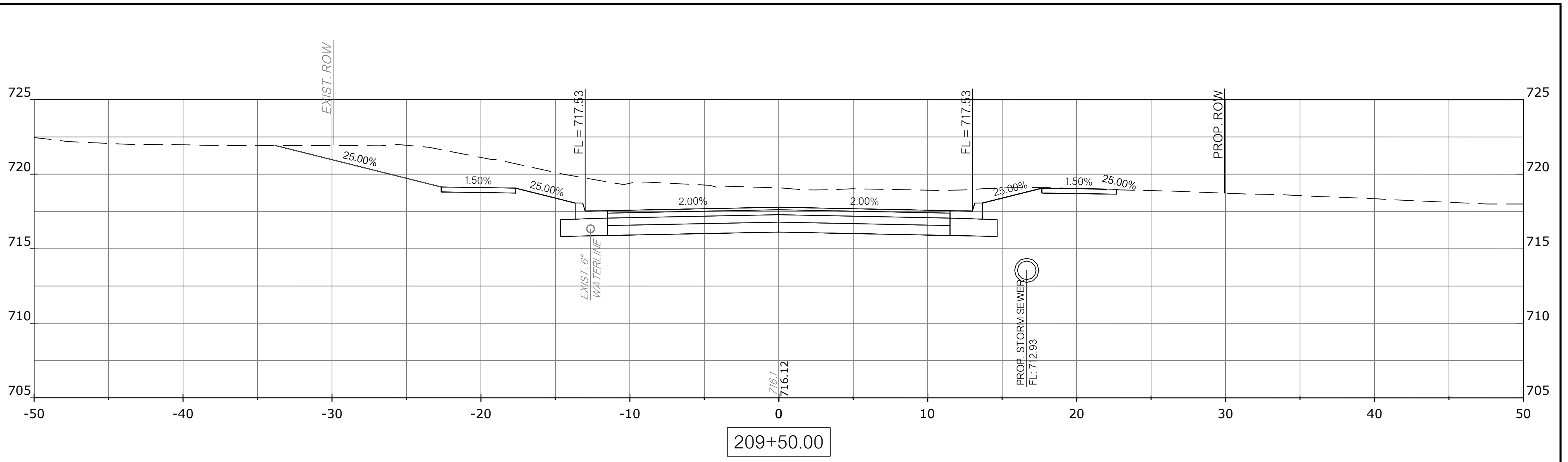

SAPULPA  
MAYFIELD STREET  
XSS OF XS6

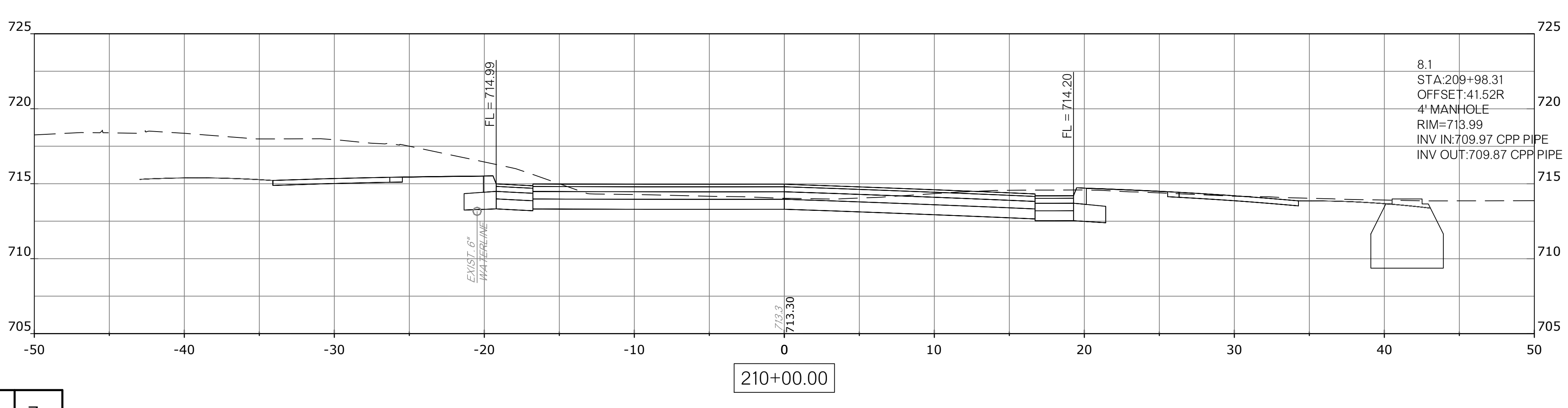
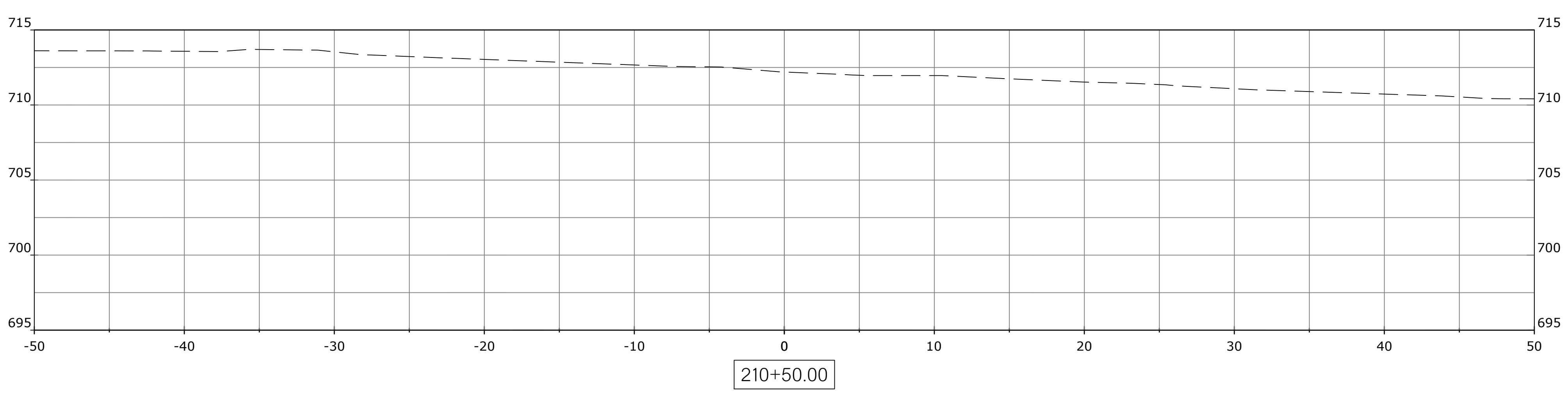

SAPULPA  
 MAYFIELD STREET  
 XS6 OF XS6

8.1  
 STA:209+98.31  
 OFFSET:41.52R  
 4" MANHOLE  
 RIM=713.99  
 INV IN:709.97 CPP PIPE  
 INV OUT:709.87 CPP PIPE